

Zehnder Carma Zehnder Neotime

Installation, Service and User Manual

always the best climate



Contents

1.	Transport and unpacking	5
1.1.	Checks during acceptance	5
1.2.	Unpacking	5
1.3.	Storage	5
1.4.	Disposal	5
1.5.	Transport and handling	5
2.	Installation conditions	6
2.1.	Space requirement	6
2.1.1.	Zehnder Neotime	6
2.1.2.	Zehnder Carma	7
2.2.	Set up	8
3.	Operating instructions	9
3.1.	General	9
3.2.	Functional description	9
3.3.	Control mode	10
3.3.1.	SEASON	10
3.3.2.	ECO	10
3.3.3.	DIVA	10
3.3.4.	LOBBY	10
3.3.5.	MAC2 (not possible with Zehnder Neotime and Zehnder Carma 9008)	11
3.3.6.	QUATTRO (not possible with Zehnder Neotime and Zehnder Carma 9008)	11
3.4.	Components	12
3.4.1.	Zehnder Neotime	12
3.4.2.	Zehnder Carma	13
3.5.	Designation of the elements in the control cabinet	16
3.5.1.	Zehnder Neotime	16
3.5.2.	Zehnder Carma	17
4.	Electrical	18
4.1.	Power supply	18
4.1.1.	Zehnder Neotime	18
4.1.2.	Zehnder Carma	19
4.2.	Control of the SEASON model	19
4.2.1.	Remote alarms	19
4.2.2.	0-10 V external (potentiometer)	20
4.2.3.	Bypass	20
4.2.4.	Automatic defrosting	20
4.3.	Control of the ECO/DIVA/LOBBY/MAC2/QUATTRO models	21
4.3.1.	Temperature sensor	21
4.3.2.	Connection terminal block	22
4.4.	Electrical connection and operation of the plate heat exchanger	23
4.5.	Automatic defrosting	23
4.6.	Connection of the filter pressure switches	24
4.7.	Connection of the fan pressure switches	24
4.8.	Connection of the pressure transducers for LOBBY MAC2 QUATTRO	24
4.9.	Connection of the motors	25
4.10.	Connection of the CO ₂ sensor	25
4.11.	Night Cooling (night-time boost ventilation)	25
4.12.	Hot water/cold water or changeover coil	26
4.13.	Direct expansion coil - cooling or changeover	27
4.14.	Electrical battery	27
4.15.	Defrosting coil	27
4.16.	Fire protection function	28
4.17.	Dehumidification function	28

Contents

4.18.	Connection of MODBUS/WEB/BACnet	29
4.19.	Connection of the signal amplifier	29
4.20.	LON	30
5.	Configuration	30
5.1.	Control (integrated or remote control)	30
5.2.	Configuration example	31
5.3.	Standard settings (operating menus)	31
5.3.1.	Operating mode menu	32
5.3.2.	Temperature control menu	33
5.3.3.	Ventilation control menu	33
5.3.4.	Time settings menu	34
5.4.	Changing the operator parameters (password 3333 required)	35
5.4.1.	Date and time setting of the timeswitches	35
5.4.2.	Changing fan speed/pressure, low speed (PV) and high speed (GV)	35
5.4.3.	Changing the temperature setpoint	36
5.4.4.	Forced switch-on or switch-off of the unit, low level (PV) or high level (GV), via remote control	36
5.4.5.	Language selection	36
5.5.	Intermediate settings (service level)	37
5.5.1.	Configuration menu at the „Service“ access level	37
5.6.	Changing the service parameters (password 2222)	38
5.6.1.	Unit control mode	38
5.6.2.	Overventilation parameters	38
5.6.3.	CO ₂ setpoint for DIVA QUATTRO option	38
5.7.	Administrator settings	39
5.7.1.	Configuration menu at the “Admin” access level	39
5.8.	Changing the admin parameters (password 1111)	40
5.8.1.	MODBUS	40
5.8.2.	Signal amplifier	40
5.8.3.	Internet communication	40
5.8.4.	BACnet	41
5.8.5.	LON communication (for CORRIGO with LON option)	41
5.8.6.	Activating the dehumidification function	41
5.8.7.	Activating the dehumidification function	41
6.	Troubleshooting	42
6.1.	Error types	42
6.2.	Alarm directory	43
6.3.	Acknowledgement of the “Perform maintenance” error	45
7.	Maintenance	46
7.1.	Mandatory maintenance	46
7.2.	Replacing the battery	46
8.	Annexes	47
8.1.	Control circuit diagram	47
8.2.	Connection of the Zehnder Neotime 600-900 motors	48
8.3.	Connection of the Zehnder Neotime 1300-1800-2500 motors	49
8.4.	Connection of the Zehnder Carma 9008 motors	50
8.5.	Connection of the Zehnder Carma 9010-9070 motors	51
8.6.	Zehnder Neotime performance graphs	52
8.7.	Zehnder Carma performance graphs	54
8.8.	MODBUS and BACnet tables	57
	Declaration UE of conformity	62

Legal regulations

All rights reserved.

This manual has been compiled with the utmost care. Nevertheless, the publisher accepts no liability for damage caused by missing or incorrect details in this operating manual. We reserve the right at any time and without prior notification to change the content of these instructions in part or as a whole.

The information contained in these documents is the property of Zehnder Group. Any form of publication, whether in whole or in part, requires the written approval of Zehnder Group. In-house duplication, designated for the evaluation of the product or for proper use, is permitted and not subject to approval.

Zehnder manufacturer's warranty

The current device terms are available online

(<https://www.caladair.com/en/espace-client/media/sales-terms-and-conditions>).

Hardcopies can be obtained via our established sales channels.

Trademarks

All trademarks are recognised, even if they are not separately labelled. A missing label does not mean that an article or sign is free of trademark rights.

© 2021 Zehnder Group

Safety notes

In accordance with the regulations in force, the installation and maintenance of the unit must only be carried out by suitably qualified personnel for this type of unit and for carrying out such operations.

Use personal protective equipment to prevent damage related to electrical hazards, mechanical hazards (injuries when handling metal sheets, sharp edges, etc.), optical hazards (UVC radiation: use safety goggles according to EN170) or acoustic hazards.

Do not use the unit for any purpose other than its intended use. This unit must only be used to supply air that is free from hazardous substances.

For transporting the unit, follow the instructions in the chapter "Transport and handling".

Carry out earthing in accordance with the applicable standards. Never operate an unearthed unit.

Before any intervention, make sure that the unit is switched off and wait until all moving parts (shutters, rotary heat exchanger, fan, etc.) have come to a standstill before opening the shutters.

During operation, the inspection doors and shutters must always be fitted and closed.

The unit is switched on and off exclusively via the repair switch.

Safety and control devices must not be removed, short-circuited or put out of operation..

When working on the unit, pay attention to the temperature that certain components can reach (water coil or electric heating battery, motor, etc.).

The installation must comply with fire safety regulations.

Waste must be disposed of in accordance with the applicable regulations.

We are not liable for any damage caused by improper use of the equipment, unauthorised repairs or modifications, or failure to comply with these instructions.

1. Transport and unpacking

The units are mounted on longitudinal beams or blocks and delivered packed in plastic film.

1.1. Checks during acceptance

On delivery of the equipment, check the condition of the packaging and the unit. In the event of damage, this should be documented as precisely as possible on the carrier's delivery note.

1.2. Unpacking

When unpacking the units, check that

- All packages are present,
- The intended accessories are present (coils, covers, electrical components, etc.).

After unpacking the units, the waste must be disposed of in accordance with the regulations in force.

No packaging may be released into the environment.

1.3. Storage

The units must be stored in a protected, dry place at a temperature between -20°C and 40°C, and the packaging should not be considered sufficient for weatherproof storage.

1.4. Disposal

Disposal of the unit must be carried out in an environmentally sound manner. Do not dispose of the unit with your household waste.

1. Check with the supplier for options to return the unit.
2. If the unit cannot be returned, check local regulations for options for recycling the components.
3. Do not dispose of the batteries of the wireless controls with normal household waste. These must be disposed of at specially designated disposal points.

1.5. Transport and handling

The units may only be transported in their installation position.

When transporting the unit with a forklift truck, make sure that the forklift truck is designed for the load capacity.

Adapt the choice for the means of transport to the weight of the delivered unit (see weight specification in the instructions).

If the unit is transported by crane, use 4 ropes of the same length. These should be at least as long as the greatest distance between 2 anchor points.

If $L + W + H > 5$ metres, the unit must be lifted using a lifting beam.

2. Installation conditions

2.1. Space requirement

As a rule, it is recommended to keep at least 0.5 times the width of the unit free on both sides for maintenance work. A siphon is required for the units. In order for the siphon to be installed, an appropriate height must be taken into account when installing the units.

2.1.1. Zehnder Neotime

Model	Ø	A	B	C	D	E	F1	F2	F3	G	G1	G2	J	K	M	M1	M2	M3	T	T1	SEASON	FIRST SMART	PREMIUM BE INFINITE BE	PREMIUM CO INFINITE CO
	mm	mm	mm	mm	mm	mm	mm	mm	mm	mm	mm	mm	mm	mm	mm	mm	mm	mm	inch	inch	kg	kg	kg	kg
600	250	1700	780	330	160	370	-	-	-	150	50	145	170	645	640	-	-	-	1/2	1/2	120	127	130	135
900	315	2020	965	415	210	460	-	-	-	150	50	145	250	760	770	-	-	-	1/2	1/2	180	190	195	200
1300	355	2190	1220	415	195	600	795	735	600	430	50	425	250	860	950	1170	510	510	1/2	1/2	255	265	270	275
1800	400	2270	1220	495	245	600	915	725	630	430	50	425	330	885	950	1110	580	580	1/2	1/2	275	285	290	295
2500	400	2395	1740	495	245	910	840	785	770	430	50	425	330	985	1350	1235	580	580	3/4	1/2	380	390	400	405

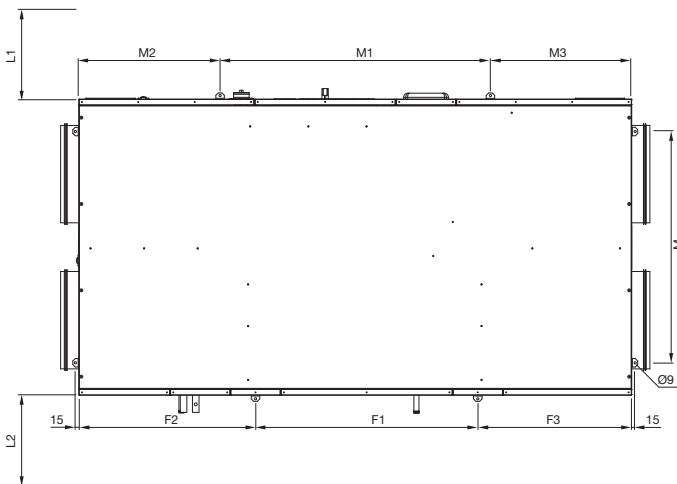
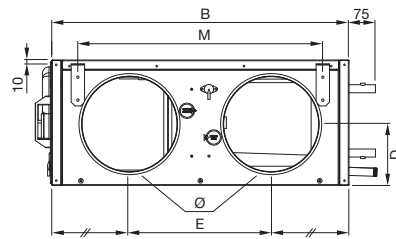
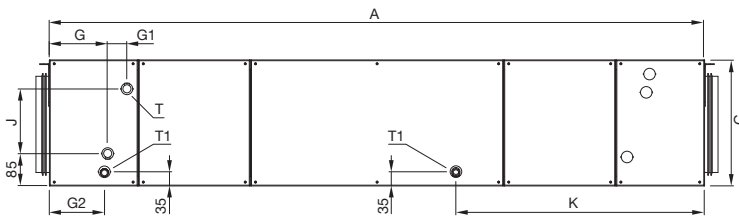

Zehnder Neotime						
Clearance for maintenance (mm)		600	900	1300	1800	2500
Access to the filter / control cabinet	L1	275	375	520	520	690
Access to the fans	L2	225	320	380	435	435
Access to the fans / to the heat exchanger / to the CO coil	L2	470	560	670	670	1020

2.1.2. Zehnder Carma

Zehnder Carma model	Ø	A	B	C	D	E	F	F1	F2	G	J	K	T	SEASON	FIRST	SMART	PREMIUM	INFINITE
	mm	mm	mm	mm	mm	mm	mm	mm	mm	mm	mm	mm	mm	kg	kg	kg	kg	kg
9008	315	2010	915	505	255	405	1097	362	517	500	245	540	1/2	210	215	217	218	220
9010	315	2010	915	505	255	405	1097	362	517	500	245	540	1/2	215	220	222	223	225
9016	400	2230	1115	605	305	505	1261	362	607	565	345	690	1/2	295	295	298	300	303
9023	450	2345	1315	705	355	605	1376	362	607	565	445	690	3/4	390	395	400	402	407
9035	500	2625	1515	805	405	705	1520	450	655	640	545	740	3/4	545	550	554	560	564
9048*	630	2970	1715	1030	455	805	1677	535	758	685	645	840	1	715	720	727	735	742
9070	see dimensions below												1	895	900	915	930	945

Horizontal arrangement (L and P)

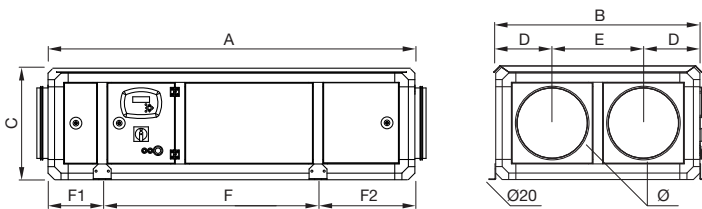

An access with dimension C is to be provided on each side.

Upright arrangement (W and Y)

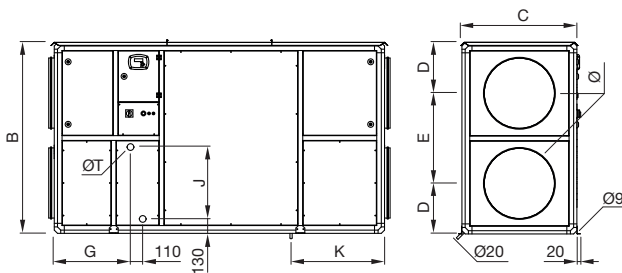

At least 300 mm must be provided on the rear side for the condensate drain.
An access with dimension C must be provided on the operating side.

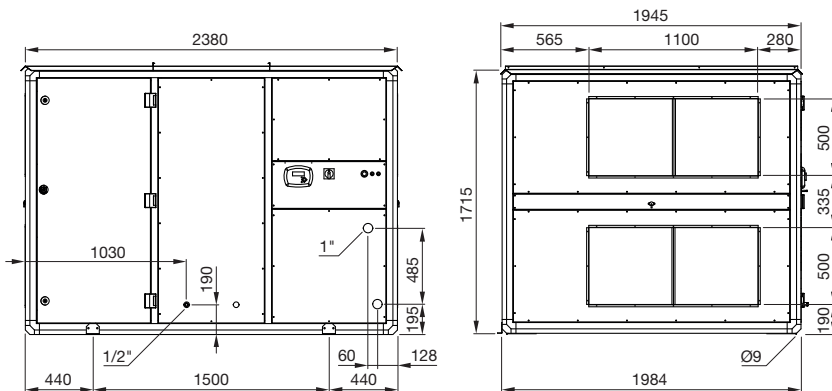

Size 9070

An access of 1100 mm must be provided on the operating side.

2.2. Set up

The unit is suitable for suspended mounting or for setting up on a sufficiently stable surface (if necessary, use anti-vibration mounts). For the air connection, the duct cross-sections are based on the dimensions of the canvas connectors, which must be properly tensioned. The ducts must be insulated if necessary, and the nearest accessory must be mounted at a distance equal to 2.5 times the diameter (T-piece, etc.). Select a set-up location for the unit where the elements inside the unit cannot be damaged by weather or surrounding temperatures during installation and subsequent use. The use of support feet (PCB) is recommended for the floor-standing models Zehnder Neotime and Zehnder Carma.

A siphon must be provided on each condensate drain.

A single siphon must not be used for several drain pipes.

Note: The siphon must be connected professionally to ensure optimum condensate drainage.

The height H must at least correspond to the maximum vacuum inside the unit (D_p in mm).

Example: $D_p = 500 \text{ Pa} = 50 \text{ mm CE}$

bei $H > 50 \text{ mm} / 2H > 100 \text{ mm}$

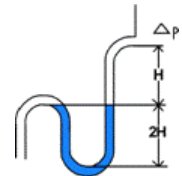

For the Zehnder Carma model, a slope of the unit of 2 to 3% in the direction of the condensate drain must be provided to drain off the condensate.

Ceiling installation: The units can be attached to the ceiling with threaded rods, depending on the weight. Mounting on a frame, taking into account the loading capacity on the ceiling construction of the building, is also possible (the installer is liable for the frame).

Outdoor installation (Zehnder Carma only): Optional support feet (PCB) are offered for mounting the unit above the floor (protected from water). A canopy (DPC) and, if necessary, inclined pipe sockets with grille (BBG) or outside/exhaust air bonnets (AGC) must be provided (offered as an option).



For NEOTIME LOBBY: Make sure to connect the pressure tube to the supply duct via the pressure socket located between extract and supply connection.

3. Operating instructions

3.1. General

The flexible ventilation solutions in the Zehnder Carma and Zehnder Neotime product ranges are equipped with highly efficient heat recovery and are suitable for installation in various properties such as offices, schools, nurseries, shopping centres, apartment buildings, restaurants, etc., both in new buildings and in renovations.

The pre-installed, pre-configured ventilation unit allows for easy plug-and-play installation, and the control unit mounted on the ventilation unit ensures easy installation, configuration and operation of the unit.

SEASON: Control of fans and bypass via potentiometer. Without connection option for a coil.

FIRST: Automatic control of fans and bypass. Enables control of an external changeover coil (or a non-integrated hot water coil and/or an external cold water coil). If desired, it is possible to connect an external electrical battery and an external cold water coil.

PREMIUM CO (Zehnder Neotime only): Automatic control of fans and bypass. Enables control of an integrated changeover coil.

PREMIUM BC (Zehnder Carma only): Economical control of fans and bypass. Enables the control of an integrated hot water coil and an additional external cold water coil.

PREMIUM BE: Automatic control of fans and bypass. Enables the control of an integrated electric battery and an additional external cold water coil.

INFINIT CO (Zehnder Neotime only): Automatic control of fans and bypass. Enables control of an integrated changeover coil and an integrated defrosting coil.

INFINITE BC (Zehnder Carma only): Automatic control of fans and bypass. Enables control of an integrated hot water battery, an integrated defrosting coil and an additional external cold water coil.

INFINIT BE: Automatic control of fans and bypass. Allows control of an integrated electric battery, an integrated defrosting coil and an additional external cold water coil.

SMART: Automatic control of fans and bypass. Allows control of an integrated defrosting coil and an external changeover coil (or an external hot water coil and/or an external cold water coil).

3.2. Function description

Except SEASON model

Commissioning:

- The extract air fan or VAR pressure control mode starts simultaneously with the exhaust air shutter.
- The supply fan or VAS pressure control mode starts after a preset time simultaneously with the outdoor air flap.
- The temperature control starts according to the configured control mode.
 - The electric heating element (if configured) is only switched on by the flow monitor.
 - Pumps that have not yet been activated are switched on.
- After a preset time, the alarm evaluation is activated. The system is then in normal operation.

Starting conditions:

The unit switches on when one of the following conditions is met:

- The time program (timeswitch) for the normal or low fan speed is set to "On".
- The system is switched on manually via the CORRIGO controller.
 - One of the digital inputs for forced switching is activated.

Shutdown:

The unit is switched off according to the following procedure:

- Deactivation of the alarm evaluation.
- Switch off the electric heating element (if configured).
- After a certain time (which is preset separately for each fan), the fans are switched off.
- The outdoor air and exhaust air shutters are closed.
- The signals to the actuators are set to zero and the pumps are stopped.

Switch-off conditions:

The unit switches off when one of the following conditions is met:

- The time program (timeswitch) for the normal or low fan speed is set to "Off" and the signal for forced switch-on is also set to "Off".
- Activation of the external switch-off command.
- The system is switched off manually via the CORRIGO controller.
- Triggering an alarm with shut-off function. The system restarts automatically as soon as the alarm is acknowledged.

3.3. Control mode

3.3.1. SEASON

1 fan speed adjustable via potentiometer.

Each fan is separately adjustable via a potentiometer integrated in the unit.

Possibility of additional remote controlled forced switch-off (standard on the power contactor (not included in the scope of delivery)).

3.3.2. ECO

1 or 2 fan speeds adjustable via display / remote control / external control "VALVE MODE (%)" (fan operation IN %).

Set a minimum level (PV - 1/2) and a maximum level (GV - 1/1) in %.

Equipped with factory-fitted timeswitch for:

- High level (GV - 1/1) from 06:00 to 22:00
- Low level (PV - 1/2) from 22:00 to 06:00

Possibility of an additional external forced switching (PV - 1/2) or (GV - 1/1).

Possibility of an additional external forced shutdown).

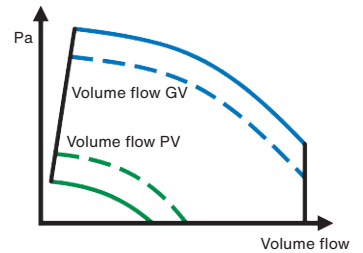

3.3.3. DIVA

Proportional control of the ventilation between two fan speeds (PV/GV) via CO₂ control "MODE AUTO CO₂" (AUTO CO₂ MODE).

Set a minimum level (PV - 1/2) and a maximum level (GV - 1/1) in %.

The CO₂ setpoint is factory-fitted to 1000 ppm (according to EPBD).

The change between (PV - 1/2) and (GV - 1/1) is made depending on the CO₂ concentration.

Equipped with factory-fitted timeswitch for permanent operation (PV - 1/2).

Possibility of an additional external forced switching (PV - 1/2) or

(GV - 1/1) (potential-free NO contacts).

Possibility of an additional external forced switch-off (potential-free NO contact).

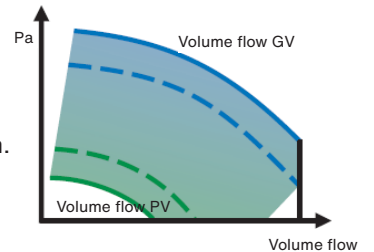

Note: In order for the CO₂ controller to function, the following conditions must be met for the system:

- Timeswitch (GV - 1/1) set to 0 (not active) (normal fan speed standby function)
- Timeswitch (PV - 1/2) in operation (low fan speed standby function)
- Forced switch-on (GV - 1/1) and forced switch-off not switched on.

3.3.4. LOBBY

Ventilation constant pressure. (Pa) "Constant pressure operation".

Setting a constant pressure (Pa).

Equipped with factory-fitted timeswitch for permanent operation (PV - 1/2).

Possibility of an additional external forced switching (PV - 1/2).

Possibility of an additional external forced shutdown.

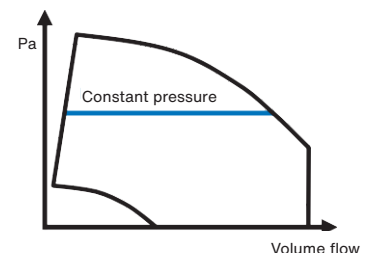

3.3.5. MAC2: (not possible with Zehnder Neotime and Zehnder Carma 9008)

Choice of 1 or 2 constant discharge capacities. (m³/h) "Constant volume operation".

Setting of 1 or 2 constant volume flows (PV - 1/2 and GV - 1/1) (m³/h).

Equipped with factory-fitted timeswitch for:

- High level (GV - 1/1) from 06:00 to 22:00
- Low level (PV - 1/2) from 22:00 to 06:00

Possibility of an additional external forced switching (PV - 1/2) and/or (GV - 1/1) (potential-free NO contacts).

Possibility of an additional external forced switch-off (potential-free NO contacts).

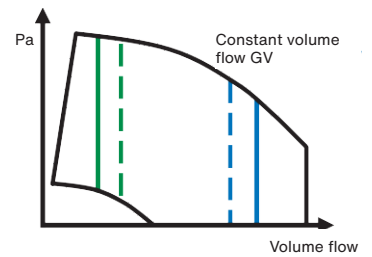
**3.3.6. QUATTRO: (not possible with Zehnder Neotime and Zehnder Carma 9008)**

Proportional control of the ventilation between 2 constant volume flows. (m³/h) depending on CO₂

Setting of a minimum (NS - 1/2) and a maximum volume flow (GV - 1/1) (m³/h).

The CO₂ setpoint is factory-fitted to 1000 ppm (according to EPBD).

The change between (PV - 1/2) and (GV - 1/1) is made depending on the CO₂ concentration.

Equipped with factory-fitted timeswitch for permanent operation (PV - 1/2).

Possibility of an additional external forced switching (PV - 1/2) (potential-free NO contacts).

Possibility of an additional external forced switch-off (potential-free NO contacts).

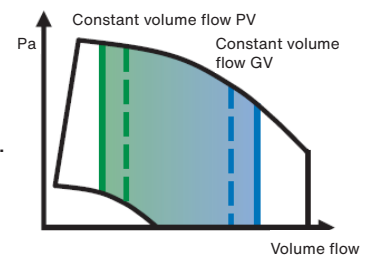

Note: In order for the CO₂ controller to function, the following conditions must be met for the system:

- Timeswitch (GV - 1/1) set to 0 (not active) (normal fan speed standby function)
- Timeswitch (PV - 1/2) in operation (low fan speed standby function)
- Forced switch-on (GV - 1/1) and forced switch-off not switched on.

3.4. Components

3.4.1. Zehnder Neotime

SEASON

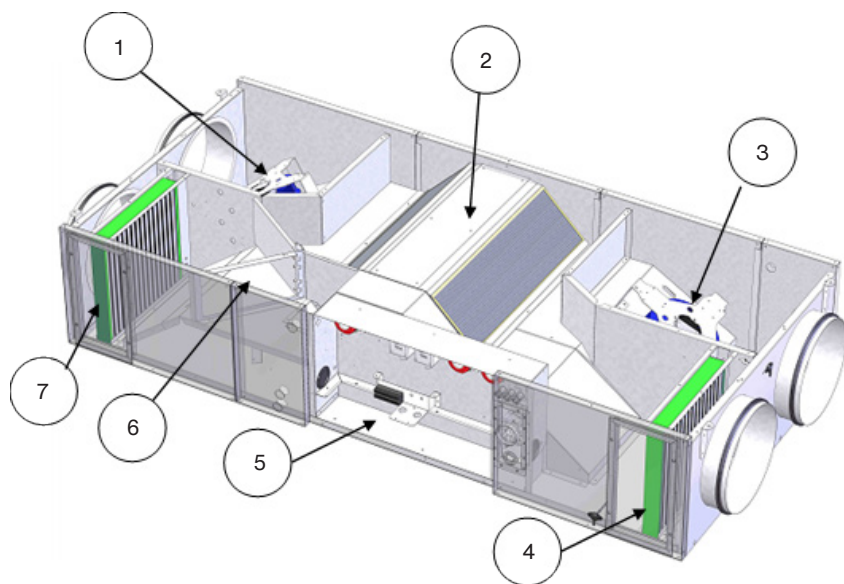

Number	Description
1	Extract air fan (VAR/VR)
2	Heat exchanger + condensate tray
3	Supply fan (VAS/VS)
4	Extract air filter FR
5	Control cabinet
6	Bypass + actuator
7	Supply air filter FS + filter pressure switch DEPFS

ECO DIVA

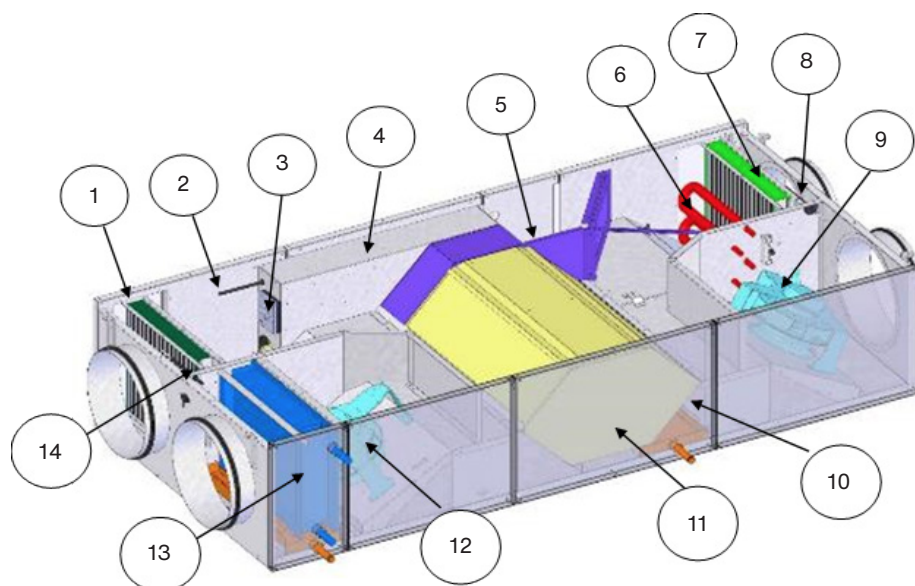

Number	Description
1	Extract air filter FR
2	Extract air temperature sensor SRG
3	CO ₂ sensor
4	Control cabinet
5	Bypass + actuator
6	Defrosting battery (SMART and INFINITE models) with defrosting battery temperature sensor SBD and safety thermostat THSD
7	Supply air filter FS + filter pressure switch DEPFS
8	External temperature sensor SEG
9	Extract air fan (VAR/VR)
10	Defrost sensor SDG
11	Heat exchanger + condensate tray
12	Supply fan (VAS/VS)
13	Changeover coil with integrated condensate tray (CO model) or electric battery (BE model)
14	Supply air temperature sensor SSG

3.5. Zehnder Carma

SEASON

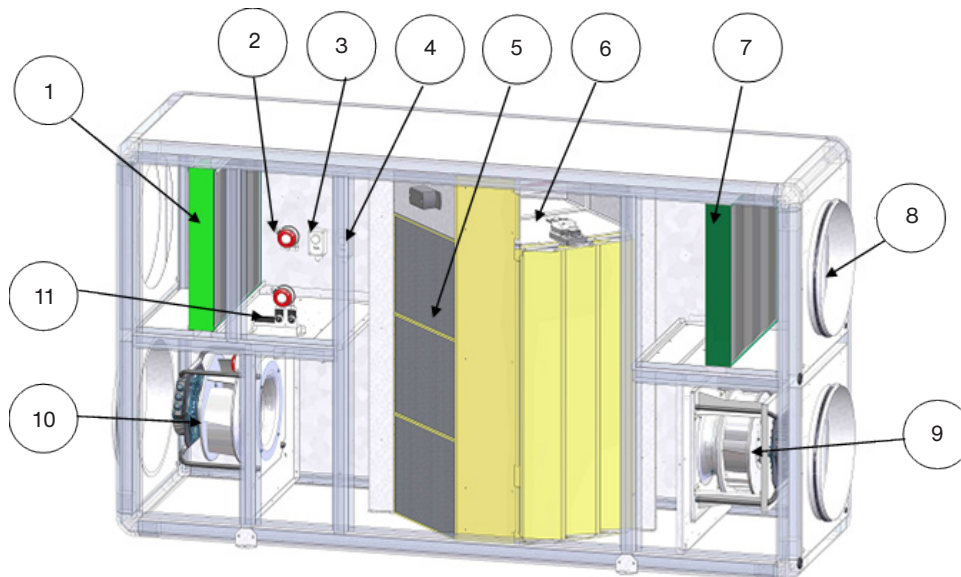

Number	Description
1	Extract air filter FR
2	Supply air pressure switch DEPS
3	TH1 winter setpoint thermostat for bypass closure (+18°C)
4	TH2 summer setpoint thermostat for bypass closure (+24°C)
5	Heat exchanger
6	Bypass
7	Supply air filter FS + filter pressure switch DEPFS
8	Defrost thermostat (+5°C)
9	Extract air fan (VAR/VR)
10	Supply fan (VAS/VS)
11	Control board

ECO DIVA MAC2 QUATTRO

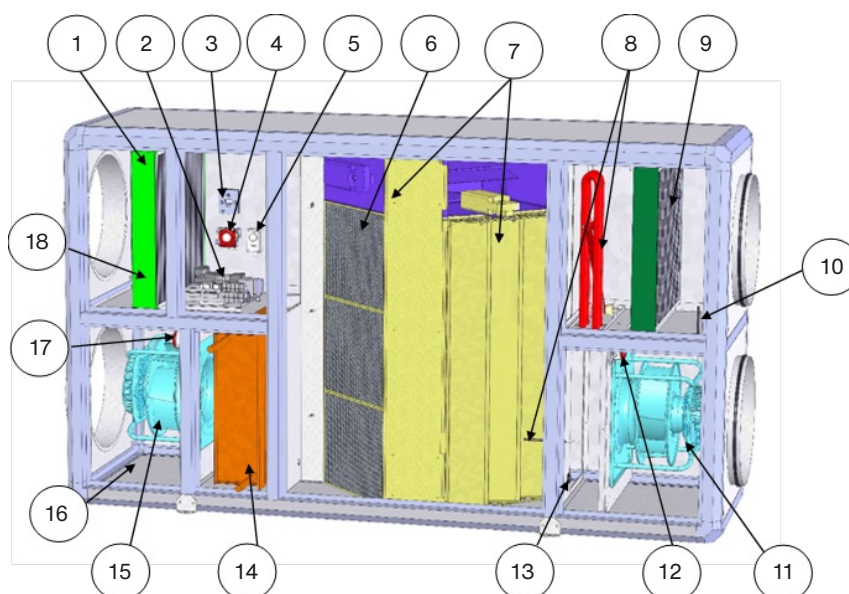

Number	Description
1	Extract air filter FR
2	Control board
3	CO ₂ sensor
4	Supply air pressure switch DEPS (ECO-DIVA model) Extract air pressure transducer TRPS (LOBBY model) Supply air pressure transducer TRPS (MAC2-QUATTRO model)
5	Frost protection thermostat THA (BC model) or safety thermostat THS (BE model)
6	Heat exchanger
7	Bypass
8	Defrosting battery (SMART and INFINITE models) with defrosting battery temperature sensor SBD and safety thermostat THSD
9	Supply air filter FS + filter pressure switch DEPF5
10	External temperature sensor SEG
11	Extract air fan (VAR/VR)
12	Extract pressure switch DEPR (ECO-DIVA model) Extract pressure transducer TRPR (MAC2-QUATTRO model)
13	Defrost sensor SD
14	Hot water coil (model BC) or electric battery (model BE)
15	Supply fan (VAS/VS)
16	Supply air temperature sensor SSG
17	Supply air pressure transducer TRPS (LOBBY model)
18	Extract air temperature sensor SRG

3.5. Designation of the elements in the control cabinet

3.5.1. Zehnder Neotime

ECO/DIVA/LOBBY controller

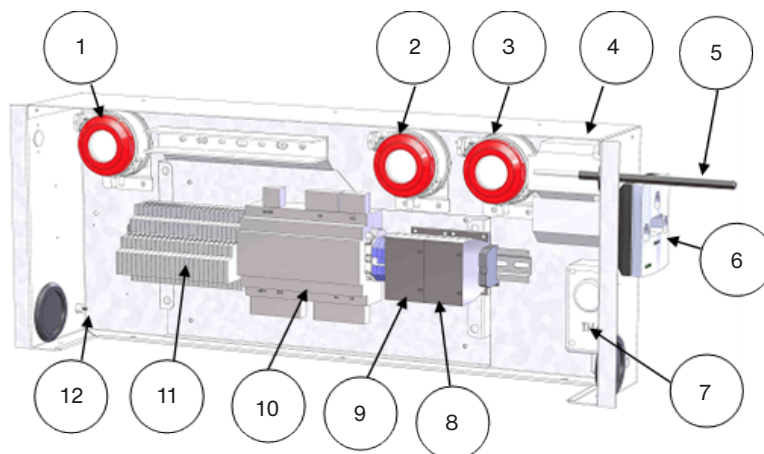

Number	Description	Description
1	DEPFS	Supply air filter pressure switch
2	DEPS or TRPS	Supply air pressure switch or supply air transformer for the LOBBY model
3	DEPR or TRPR	Extract air pressure switch or extract air pressure transducer for the LOBBY model
4	Control unit	Control-power transformer 230/24 V
5	SRG	Extract air temperature sensor
6	CO ₂	CO ₂ sensor (only for DIVA model)
7	THA	Frost protection thermostat (CO model)
8	K1	Relay of the electric heating battery
9	KD	Relay of the electric defrosting battery
10	Controller	CORRIGO controller E283W3
11	Terminal block	Control terminal block
12	THSD	Safety thermostat on defrosting battery (SMART and INFINITE models)

SEASON controller

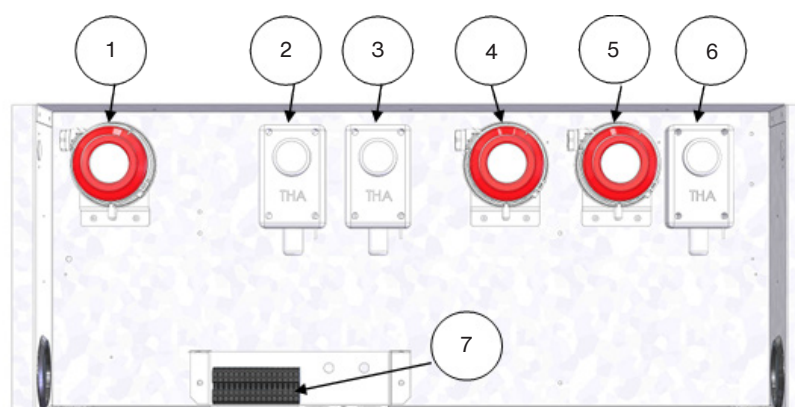

Number	Description	Description
1	DEPFS	Supply air filter pressure switch
2	TH1	Winter setpoint thermostat for bypass closure (+18°C)
3	TH2	Summer setpoint thermostat for bypass closure (+24°C)
4	DEPS	Supply air pressure switch
5	DEPR	Extract air pressure switch
6	TH3	Defrost thermostat (+5°C)
7	Terminal block	Connection terminal block

3.5.2. Zehnder Carma

ECO/DIVA/LOBBY/MAC2/QUATTRO controller

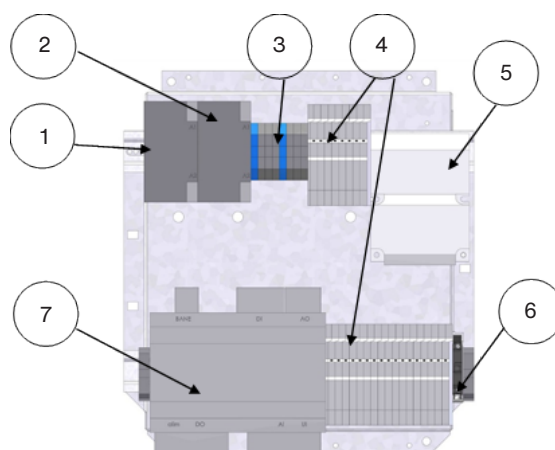

Number	Description	Description
1	K1	Electric defrosting coil contact
2	KD	Electric heating coil contact
3	Terminal block	Terminal block for the power supply to the fan
4	Terminal block	Control terminal block
5	Control unit	Control-power transformer 230/24 V
6	BFUS	Fuse terminal
7	Controller	CORRIGO controller E283W3

SEASON controller

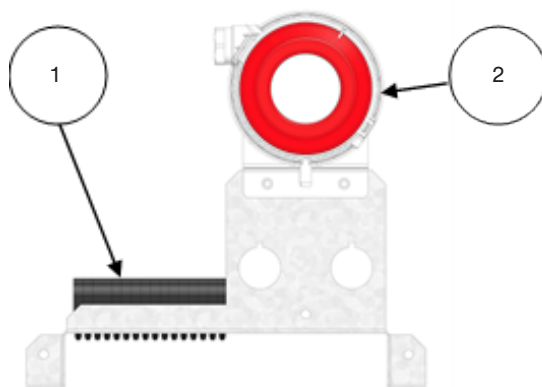

Number	Description	Description
1	Terminal block	Connection terminal block
2	DEPR	Extract air pressure switch

4. Electrical

4.1. Power supply

4.1.1. Zehnder Neotime

Model	Output Electric-motor (W)	Operating temp. (°C / °C)	Degree of protection	Thermal protection class *	FIRST, PREMIUM CO and SEASON		INFINITE CO and SMART		PREMIUM BE			INFINITE BE		
					Supply voltage (V/Ph/Hz)	Current draw (A)	Supply voltage (V/Ph/Hz)	Current draw (A)	Supply voltage (V/Ph/Hz)	Model	Current draw (A)	Supply voltage (V/Ph/Hz)	Model	Current draw (A)
600	2 x 169	-20 / 60	IP54/B	PTI	230/1/50	2.8	230/1/50	8.2	230/1/50	-	8.2	230/1/50	-	13.7
900	2 x 220	-20 / 60	IP44/B	PTI	230/1/50	3.4	230/1/50	14.3	230/1/50	-	11.0	230/1/50	-	21.9
1300	2 x 400	-20 / 40	IP44/B	PTI	230/1/50	8.6	230/1/50	23.6	230/1/50	-	19.5	230/1/50	-	34.7
1800	2 x 400	-20 / 40	IP44/B	PTI	230/1/50	8.6	230/1/50	24.9	400/3+N/50	-	24.9	400/3+N/50	-	15.1
2500	2 x 400	-20 / 40	IP44/B	PTI	230/1/50	8.6	230/1/50	31.4	400/3+N/50	-	31.4	400/3+N/50	-	19.5

* PTI: Integrated thermal protection

4.1.2. Zehnder Carma

Zehnder Carma model	Output Electric-motor (W)	Operating temp. (°C / °C)	Degree of protection	Thermal protection class *	FIRST, PREMIUM BC and SEASON		INFINITE BC and SMART		PREMIUM BE			INFINITE BE		
					Supply voltage (V/Ph/Hz)	Current draw (A)	Supply voltage (V/Ph/Hz)	Current draw (A)	Supply voltage (V/Ph/Hz)	Model	Current draw (A)	Supply voltage (V/Ph/Hz)	Model	Current draw (A)
9008	2 x 220	-20 / 60	IP44	B PTI	230/1/50	3.4	230/1/50	14.3	230/1/50	BE 025	14.3	230/1/50	BE 025	25.2
9010	2 x 480	-20 / 60	IP54	B PTI	230/1/50	4.3	230/1/50	20.6	230/1/50	BE 025	15.2	230/1/50	BE 025	31.5
9016	2 x 480	-20 / 60	IP54	B PTI	230/1/50	4.3	400/3+N/50	11.9	230/1/50 400/3+N/50	BE 037 BE 052	20.6 11.9	400/3+N/50	BE 052	19.5
9023	2 x 700	-20 / 40	IP54	B PTI	230/1/50	6.0	400/3+N/50	15.7	230/1/50 400/3+N/50	BE 037 BE 067	22.3 15.7	400/3+N/50	BE 067	25.4
9035	2 x 2500	-20 / 40	IP54	B PTI	400/3+N/50	7.7	400/3+N/50	19.6	400/3+N/50	BE 067 BE 137	17.4 27.2	400/3+N/50	BE 067 BE 137	29.3 39.1
9048	2 x 1950	-20 / 50	IP54	B PTI	400/3+N/50	6.3	400/3+N/50	32.3	400/3+N/50	BE 067 BE 137	16.0 25.8	400/3+N/50	BE 067 BE 137	42.0 51.8
9070	2 x 2730	-20 / 60	IP54	F PTI	400/3+N/50	8.4	400/3+N/50	44.1	400/3+N/50	BE 105 BE 157	23.6 31.1	400/3+N/50	BE 105 BE 157	59.4 66.9

* PTI: Integrated thermal protection

4.2. Control of the SEASON model

The components are connected at the factory (see chapter “Complete circuit diagram”).

4.2.1. Remote alarms

A remote alarm can be connected directly to the following pressure switches:

- DEPS = supply air pressure switch
- DEPR = extract air pressure switch
- DEPFS = filter pressure switch (NO contact for Zehnder Carma available on the terminal block (terminals 25-26))

- 1 Supply line (COM)
 2 Normally closed contact (NC)
 3 Normally open contact (NO)

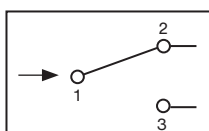

Attention: max. 5 A / 230 VAC and max. 4 A / 24 VDC

4.2.2. 0-10 V external (potentiometer)

The fan potentiometers are connected at the factory. There is the option of replacing them with remote potentiometers or external 0-10 V potentiometers. To connect an external element, disconnect the cables on the back of the potentiometers and connect directly to these cables.

Current connection

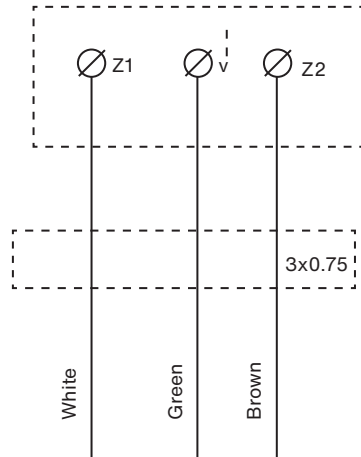

White = 0 V = Z1
 Green = 0-10 V = to
 Braun = +10 V = Z2

4.2.3. Bypass

The thermostats are set at the factory:

TH1 = outdoor temperature for heat recovery via heat exchanger (factory setting 18°C)

TH1 = outdoor temperature for cold recovery via heat exchanger (factory setting 24°C)

The heat exchanger bypass is connected at the factory (see circuit diagram chapter IV.2).

Its operation is automatic via two thermostats:

In winter:

When the outdoor temperature drops below 18°C (adjustable), the bypass closes and allows maximum heat recovery.

In summer:

Cold recovery: When the outdoor temperature rises above 24°C (adjustable), the bypass closes and enables maximum cold recovery.

FREE COOLING: When the temperature is between 24°C and 18°C (adjustable), the bypass is open so that the outdoor air can flow in directly.

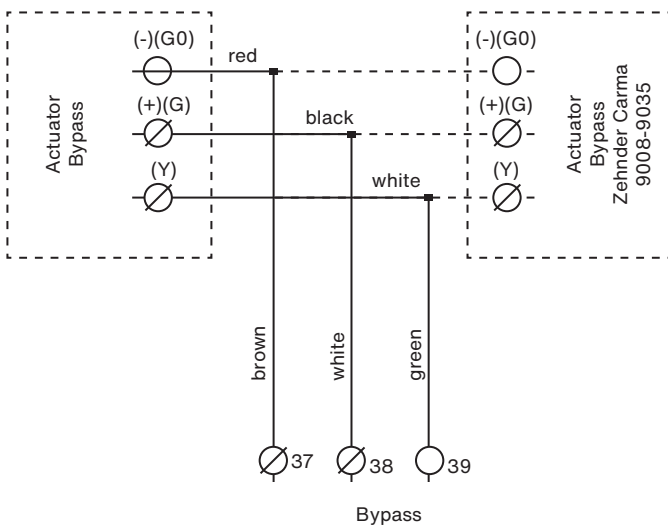

(Set Zehnder Neotime 2500 actuator to L)

4.2.4. Automatic defrosting

Defrosting takes place by opening the bypass as soon as the defrosting temperature (SDG) falls below 5°C (thermostat installed at the outlet). As soon as the temperature rises above +5°C again, the bypass closes.

4.3. Control of the ECO/DIVA/LOBBY/MAC2/QUATTRO models

4.3.1. Temperature sensor

The temperature sensors are connected directly to the controller.

- SSG: Supply air temperature sensor on AGND(30) and AI1(31)
- SEG: External temperature sensor on AGND(30) and AI2(32)
- SDG: Defrost temperature sensor on AGND(33) and AI3(34)
- SRG: Extract air temperature sensor on AGND(33) and AI4(35)
- SBD: Defrosting element temperature sensor on AGND(40) and UI1(41) on SMART and INFINITE models (replaced by 1030 ohm resistor on other models)

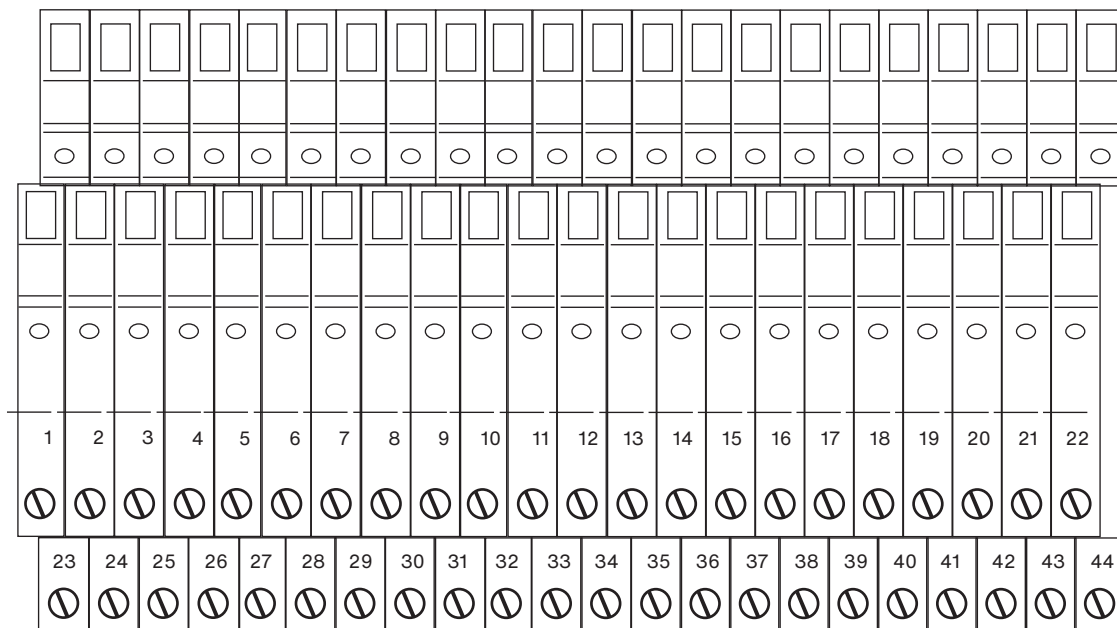

4.3.2. Connection terminal block

See chapter 3.5 pages 14 and 15.

Description	Terminals	Connection
ADP (bypass when not in use)	1-2	Connection to the terminals of an NC contact of the fire alarm remote switch-off
DAD (bypass when not in use)	3-4	Connection to the fault contact DAD
THA / THS (bypass if not used)	5-6	Connection to the NC contact of the THA (PREMIUM BC/CO and INFINITE BC/CO) or Connection to the NC contact of the THS (PREMIUM BE and INFINITE BE)
ED-TOUCH	7-8 + A*-B* (Port2)	Connection to external touch screen
MF PV	9-10	Connection to the external potential-free NO contact of the forced switch-on low fan speed
MF GV	11-12	Connection to the external potential-free NO contact of the forced switch-on high fan speed
ARR EXT	13-14	Connection to the external potential-free NO contact of the external forced switch-off
BC	15-16-17	BC: Connection to the three-way valve of the hot water coil (see chapter IV.12)
BE	18 + DO3**	BE: Connection to the relay of the electrical battery (see chapter IV.14)
Heat pump	18 + DO3**	Connection to the function ON/OFF button of the hot water circulation pump (Attention: max. 24 V 2 A via relay) (see chapter IV.12)
Cold pump	19 + DO4**	Connection to the function ON/OFF button of the cold water circulation pump (Attention: max. 24 V 2 A via relay)** (see chapter IV.12)
AL	20 + DO5**	24 V output available if unit fails (Attention: maximum 24 V 2 A via relay)
DBE	21 + DO6**	Connection to the terminals of the defrosting coil relay (see chapter IV.15)
NC (Night Cooling) (LOBBY)	22 + DO7**	24 V output available when the unit is connected with the LOBBY EC option to open the shutters in the Night Cooling phase. (Attention: maximum 24 V 2 A via relay)
TRPS (LOBBY MAC2 QUATTRO)	23 AGND* + UI2*	Connection to the supply air pressure transducer (see chapter IV.9)
DEPS (ECO, DIVA)	24 + UI2*	Connection to terminals 1 and 3 of the supply pressure switch (see chapter IV.7)
TRPR (LOBBY MAC2 QUATTRO)	25 AGND* + UI3*	Connection to the extract air pressure transducer (see chapter IV.8)
DEPR (ECO, DIVA)	26 + UI3*	Connection to terminals 1 and 3 of the extract air pressure switch (see chapter IV.7)
CO₂ (DIVA)	27 AGND* UI4*	Connection to the CO ₂ sensor (see chapter IV.10) For DIVA option
BF	28-29-30	BF: Connection to the three-way valve of the cold water coil (see chapter IV.12)
DEPFS DEPFR	31-32 33-34	Connection to terminals 1 and 3 of the supply air filter pressure switch (see chapter IV.6) Connection to terminals 1 and 3 of the extract air filter pressure switch (see chapter IV.6)
RMS	35 + DO1**	Connection to terminals 1 and 2 of the outdoor air flap
RMR	36 + DO2**	Connection to terminals 1 and 2 of the exhaust air flap
BIM	37-38-39	Connection to the valve actuator of the motorised bypass (see chapter IV.4)
0-10V S	40-41	Connection to the supply fan (see chapter "Annexes")
0-10V R	42-43	Connection to the extract air fan (see chapter "Annexes")

* Connection directly to the CORRIGO controller

** Connection directly to the CORRIGO controller and a maximum of 8 A to all DO

4.4. General

The heat exchanger bypass is connected at the factory.

Its operation is automatically controlled via the programming of the CORRIGO controller and via the sensors installed as standard in our units.

In winter:

When heating is required, the bypass closes gradually until it is completely closed to ensure maximum heat recovery. If this is not sufficient to reach the setpoint temperature, the heating coil is used.

In summer:

Cold recovery: When the outdoor temperature is higher than the indoor temperature and cooling is required, the bypass closes gradually until it is completely closed to ensure maximum cold recovery. If this is not sufficient to reach the setpoint temperature, the cooling coil is used.

FREE COOLING: If the outdoor temperature is below the room temperature and there is a need for cooling, the bypass opens gradually until it is completely open and fresh outdoor air can be fed into the interior of the building cost-neutrally. If this is not sufficient to reach the setpoint temperature, the cooling coil is used.

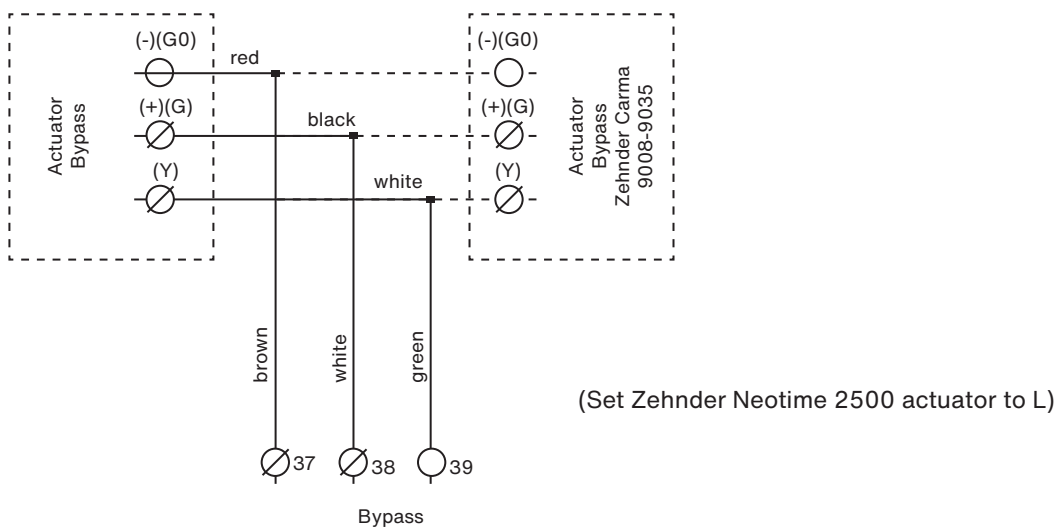

4.5. Automatic defrosting

This function, which cannot be regulated, is automatically controlled via the programming of the CORRIGO controller and via the sensors installed as standard in our ventilation units. Defrosting starts by opening the bypass as soon as the defrosting temperature (SDG) falls below 5°C (temperature sensor installed at the outlet). If the bypass is not sufficient to defrost the heat exchanger (at outdoor temperatures below -10°C), the supply fan adjusts its discharge capacity to maintain the temperature at the defrost sensor at 5°C.

On the SMART INFINITE BE and INFINITE BC/CO models, the defrosting battery is mounted on the fresh air supply upstream of the plate heat exchanger. It regulates the heat exchanger to an inlet temperature of -5°C. This eliminates the risk of ice formation and keeps the bypass closed as much as possible. This ensures a maximum level of efficiency of the system. If the defrosting battery is not sufficient to defrost the heat exchanger, the modulation function of the bypass and then the fan are used as described above.

4.6. Connection of the filter pressure switches

The supply air filter pressure switch is wired and connected at the factory.

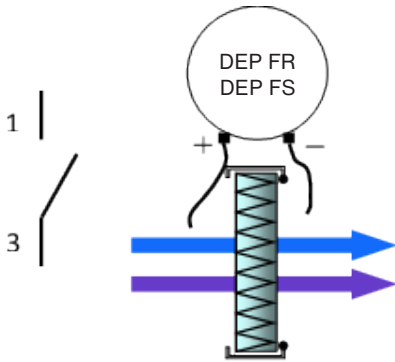

4.7. Connection of the fan pressure switches

The fan pressure switches are factory-wired and connected for ventilation.

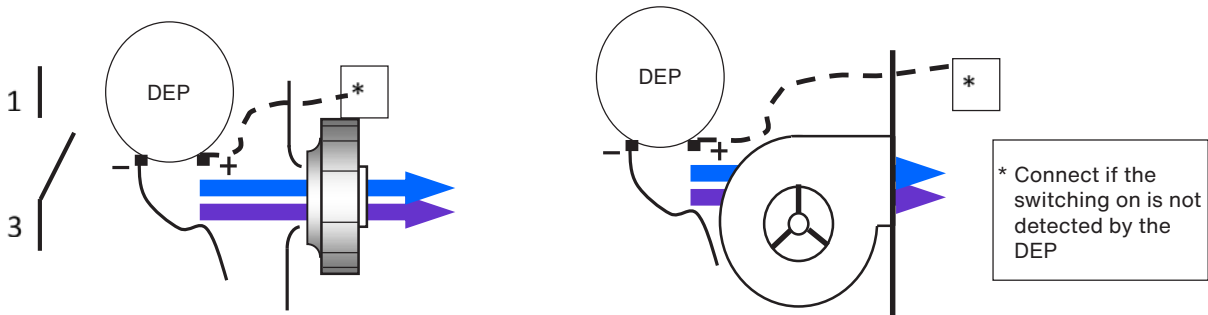

4.8. Connection of the pressure transducers for LOBBY, MAC2, QUATTRO

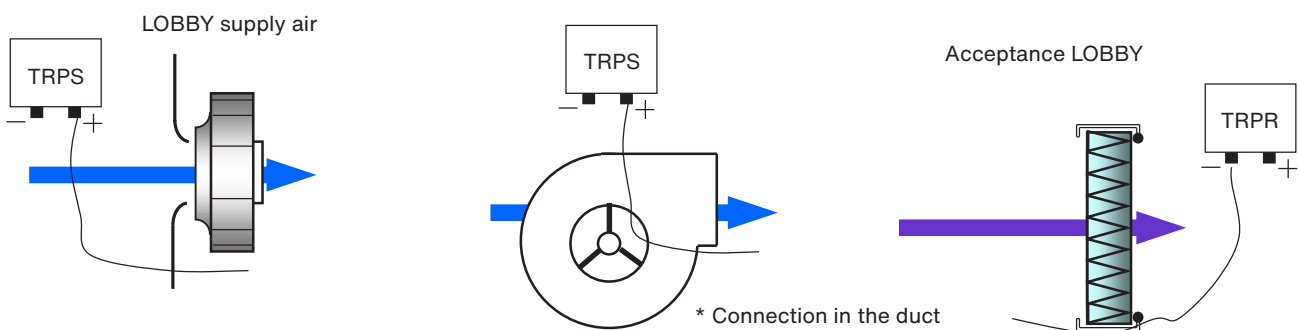
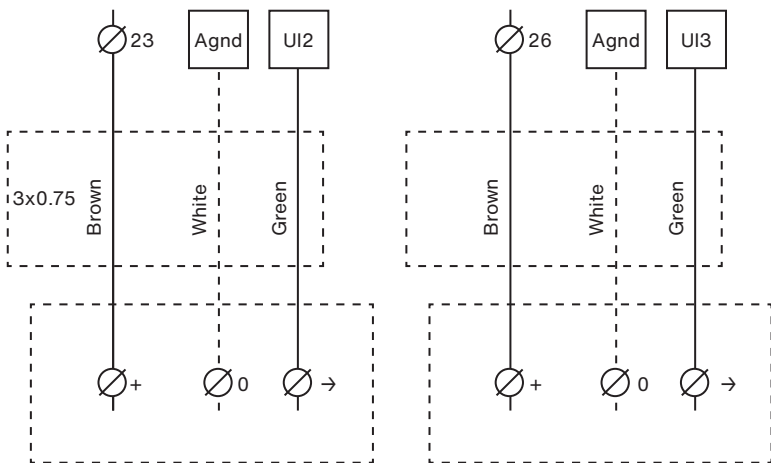

4.9. Connection of the motors

See chapter “Annexes”

4.10. Connection of the CO₂ sensor

The CO₂ sensor is wired at the factory (DIVA/QUATTRO option).

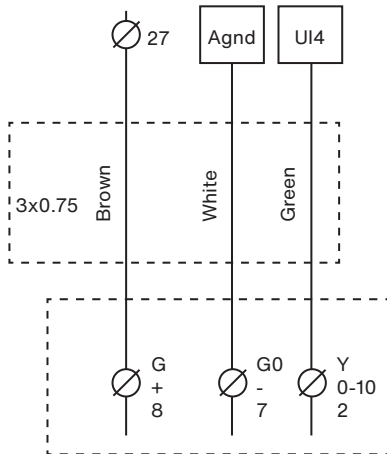

4.11. Night Cooling (night-time boost ventilation)

This function is used in summer to cool buildings at night with the help of fresh outdoor air. This means that less cooling power has to be provided during the day. The Night Cooling function is only available from 00:00 to 07:00. In the Night Cooling phase, the heating and cooling coils are blocked at 0 V. The heat exchanger switches to fresh air. At the end of a Night Cooling phase, the heating is blocked for 60 minutes at 0 V.

Operating conditions configurable according to chapter V.5.b.2

- The outdoor temperature was above 22°C during the day.
- The timeswitches are set either to PV or to switch off between 00:00 and 07:00.
- The outdoor temperature is below 18°C during the Night Cooling phase.
- The outdoor temperature is above 10°C during the Night Cooling phase.
- The room temperature is higher than 18°C.

In the Night Cooling phase, the fans run at 85%. This fan speed is adjustable (see chapter V.5.a).

In the LOBBY model, a 24 V output (connection via relay) is available between terminals 22 and DO7 for forced opening of the volume flow controllers in the night cooling phase.

4.12. Hot water/cold water or changeover coils

For PREMIUM BC and INFINITE BC or FIRST units with changeover or cooling module, a condensate drain via siphon must be provided. Make sure that the access panels (pipes, cables, etc.) can be opened unimpeded.

The coil is already installed in the unit and the frost protection thermostat is connected. However, the 3-way valve still has to be wired. If you use a cooling or changeover coil, move the supply air sensor behind the coil.

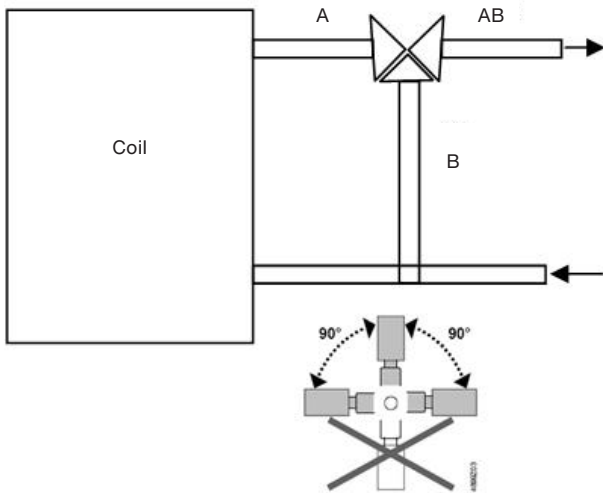

Disconnect the unit from the mains before connecting the valve
 Connect the valve actuator of the 3-way valve as follows:

Heating coil:

Terminal **15** at +24 V (G) of the valve actuator

Terminal **16** at 0 V (G0) of the valve actuator

Terminal **17** at 10 V (Y) of the valve actuator

Connect the NC contact (C and 2) of the antifreeze thermostat **THA** to 5 and 6.

Possibility of connecting the hot water circulation pump to the unit via terminals **DO3 of the controller and 18 of the terminal block.** (Note: Connection 24 V output via relay)

Cooling coil:

Terminal **28** at +24 V (G) of the valve actuator

Terminal **29** at 0 V (G0) of the valve actuator

Terminal **30** at 10 V (Y) of the valve actuator

Connect the NC contact (C and 2) of the antifreeze thermostat **THA** to 5 and 6.

Possibility of connecting the cold water circulation pump to the unit via terminals **DO4 of the controller and 19 of the terminal block.** (Note: Connection 24 V output via relay)

Changeover coil:

The changeover valve must be installed upstream of the mixer in the flow.

The 3-way valve and the change-over valve must be wired.

Connect the assembly as follows:

Red cable of the changeover valve (CO) to 10 V (Y) of the valve actuator

Terminal **15** at +24 V (G) of the valve actuator

Terminal **16** at 0 V (G0) of the valve actuator

Terminal **17** to the brown cable of the change-over valve (heating signal)

Terminal **30** to the black cable of the change-over valve (cooling signal)

Connect the NC contact (C and 2) of the antifreeze thermostat **THA** to 5 and 6.

Option for connecting the circulation pump to the terminals **DO3 of the controller and 18 of the terminal block** (heating requirement) and to the terminals **DO4 of the controller and 19 of the terminal block** (cooling demand). (Note: Connection 24 V output via relay)

NOTE: In this case, use a relay for each output and wire it in parallel with the relay of the circulation pump.

4.13. Coil for direct evaporation - cooling only or switchable

On units with DX coil, the additional module is equipped with a condensate tray.

A condensate drain via a siphon must be provided.

The following is provided:

- a 24 V output when heating or cooling is required
- a 0-10 V heating output and a 0-10 V cooling output.

Heating requirement:

- 24 V output: Connection to terminals DO3 of the controller and 18 of the terminal block so that a start command can be sent to control a DX module (caution: maximum 24 V/2 A via relay).
- 0-10 V output: Connection to terminals 16 and 17 (16 = 0 V and 17 = 0/10 V)

Cooling requirement:

- 24 V output: Connection to terminals DO4 of the controller and 19 of the terminal block so that a start command can be sent to control a DX module (caution: maximum 24 V/2 A via relay).
- 0-10 V output: Connection to terminals 29 and 30 (29 = 0 V and 30 = 0/10 V)

Attention: In case of a 24 V output is used, make a relay between each output and cable them in parallel on the M/A of the direct expansion module.

Attention: The command 24 V et 0-10 V start do not manage any safety or, anti court cycle ... of the direct expansion module.

4.14. Electrical battery

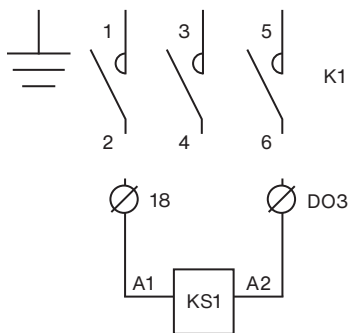

Zehnder Neotime 600-1300
 Zehnder Carma 9008-9010
 Zehnder Carma 9016 037
 Zehnder Carma 9023 037BE

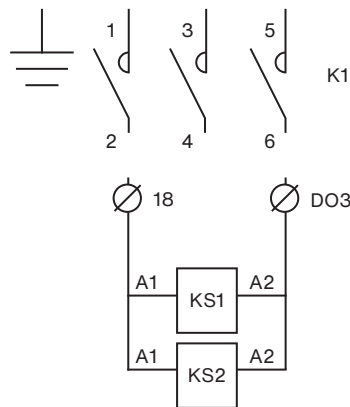

Zehnder Neotime 1800-2500
 Zehnder Carma 9016 067
 Zehnder Carma 9023 067
 Zehnder Carma 9035-9070

4.15. Defrosting battery

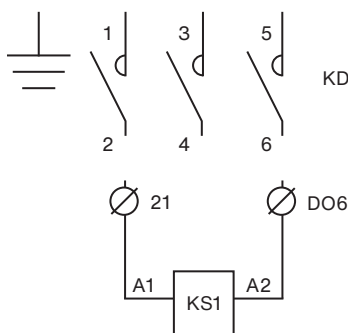

Zehnder Neotime 600-1300
 Zehnder Carma 9008-9010

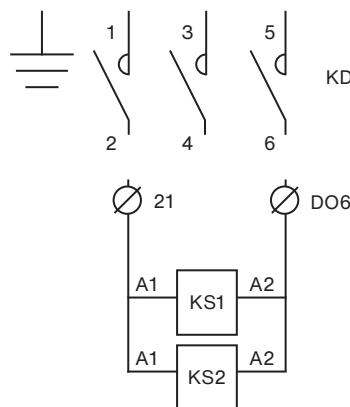

Zehnder Neotime 1800-2500
 Zehnder Carma 9016-9070

4.16. Fire protection function

See configuration in chapter V.8

The fire protection function can be controlled in 2 ways:

- Switch-off by the fire alarm contact: Connection between terminals 1 and 2 (potential-free NC contact). Complete switch-off of the unit control (indicator no longer available).
- Fire alarm: This function allows control of the supply and extract fans according to 5 operating modes available in the control parameters (function can be activated locally). In this case, an alarm is displayed on the “Fire alarm” page.
 1. “Stop”: Complete switch-off of the unit
 2. “Permanent operation”: Commissioning or operation of the unit on GV. The fire protection function has priority over all other alarms.
 3. “Normal operation”: Operation of the unit depending on the configuration at the place of use (Stop/PV/GV).
 4. “Supply fan only”: Commissioning or operation of the supply fan on GV (extract air off)
 5. “Extract fan only”: Commissioning or operation of the extract fan on GV (supply air off).

The digital input “Stop ext.” has priority over the fire protection function.



This function is not suitable for the French market and must in any case be validated by an inspection body.

The digital input for the fire alarm must be connected between terminals DI8 of the controller and 13 of the terminal block (potential-free contact required).

4.17. Dehumidification function

See configuration in chapter V.8

The unit can be connected to a Combox Concept module equipped with a cooling coil (water or DX cold only) followed by a heating coil (water, electric or DX hot). In this case, the supply of the amount of warm or cold air required for dehumidification is automatically adjusted via the controller, while maintaining the optimum operating temperature. Within the period with cooling demand, temperature control is prioritised over the dehumidification.



The function is not available in DIVA/QUATTRO mode.

Connect the coils according to the instructions in chapters IV.12 and IV.14.

Position the humidity sensor on the supply or extract air duct, depending on the type of humidity control. For room humidity control for an extract air unit without recovery, a room humidity sensor must be positioned in your building. This must be installed in a neutral location (without interference from external influences).

Connect the humidity sensor as follows:

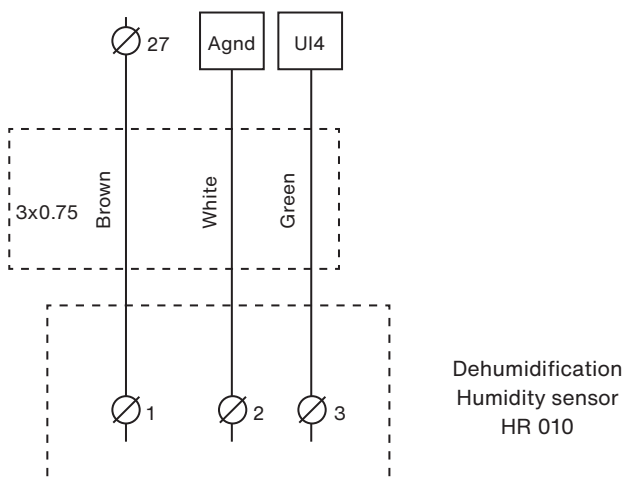

4.18. Connection of MODBUS, WEB, BACnet

(see configuration in chapter V.8)

MODBUS RS485 and BACnet MS/TP: Use a shielded twisted pair cable of the type BELDEN 8723 or equivalent to connect the BMS to the controller (connect to port 1 (BANE) / connect shield to N and do not connect E).

WEB / MODBUS TCP/IP and BACnet IP: Connection to the TCP/IP port

BMS: en standard

MODBUS / RS485 or TCP/IP

WEB / TCP/IP

BACnet / TCP/IP or MSTP

EXO / TCP/IP

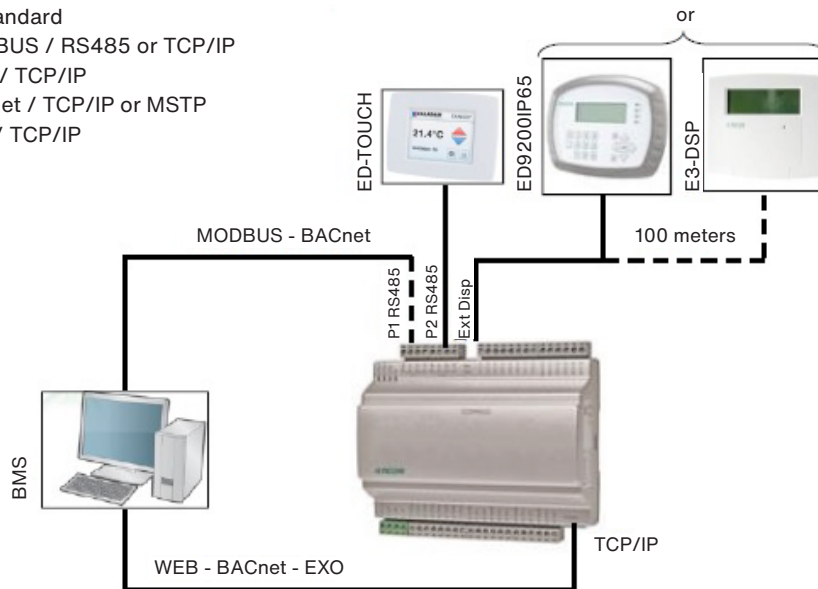

4.19. Connection of the signal amplifier

(see configuration in chapter V.8)

A signal amplifier is required in the following cases:

- Connecting more than one unit (maximum 6) to one screen
- Use of a remote control from a distance of more than 100 m

In this case, the remote control works from a distance of up to 1 km. For wiring, a shielded twisted pair cable of the type BELDEN 8723 or equivalent between the signal amplifier and the controller. Wire the single-phase 230 V power supply.

Connect the wires to port 1 as follows:

- B of the signal amplifier to terminal B of the controller (core of the shielded cable as in the illustration below)
- A of the signal amplifier to terminal A of the controller (core of the shielded cable as in the illustration below)
- N of the signal amplifier to terminal N of the controller (shielding of the shielded cable as in the illustration below)

A single-phase 230 V power supply must be provided at the signal amplifier.

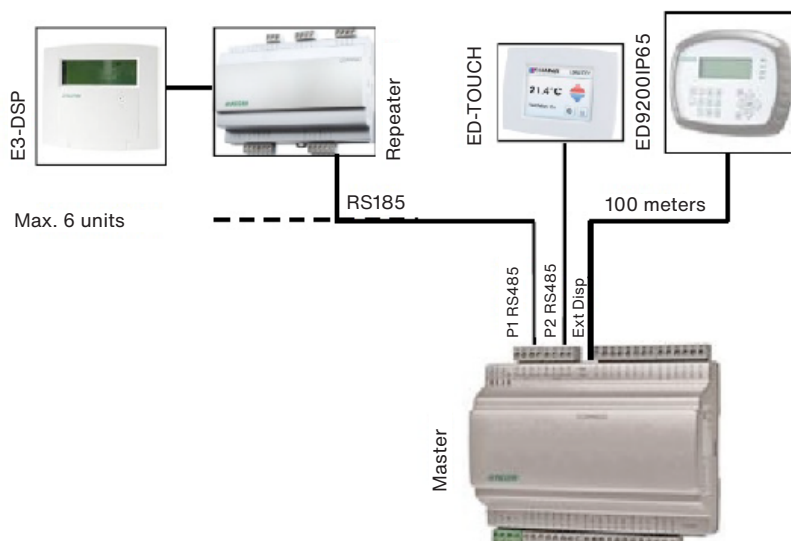

4.20. LON

(see configuration in chapter V.8) port 2 of the master with port 1 of the LON controller.

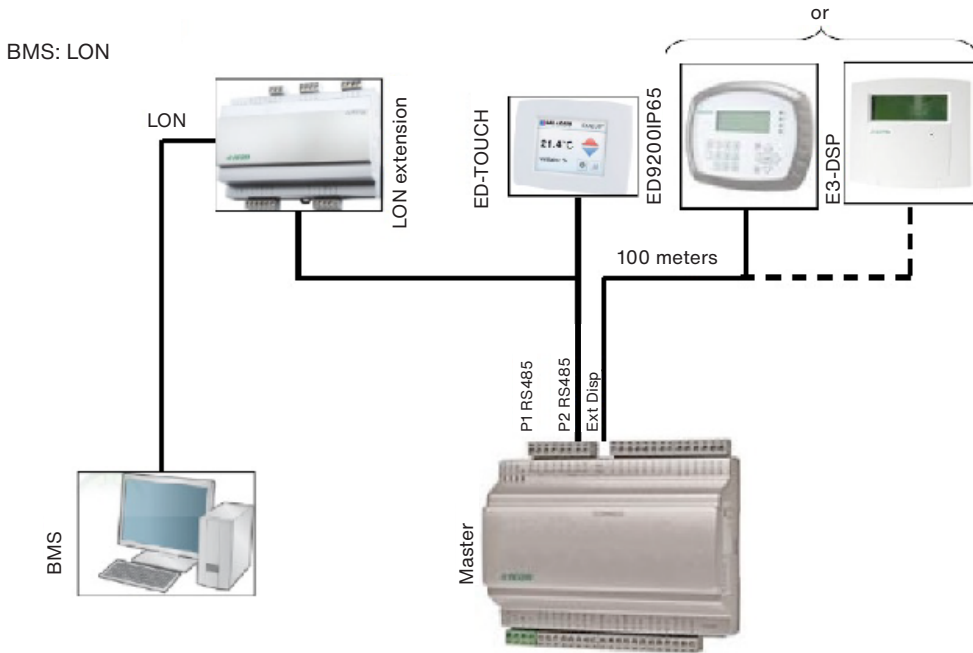

5. Configuration

5.1. Control (integrated or remote control)

The display has four lines of twenty characters each and is backlit. This lighting is not permanently switched on, but is activated by pressing a key. The lighting switches off again after a certain period of inactivity.

There are two LEDs on the front panel:

The alarm LED, represented by the bell symbol. 🔔

The input LED, represented by the pen symbol. ✎

- Fast flashing = value can be edited
- Slow flashing = A password must be entered to edit a value
 - Use the up, down, left and right arrow keys to navigate through the menus.
 - The up and down arrow keys can be used to increase or decrease the value of a parameter at the respective access level, while the right and left arrow keys are used to navigate within a parameter value.
 - Press the OK key to confirm the entry or a selection; press the C key to delete it.
 - The alarm key (red) gives access to the error list.
 - Use the arrow key pointing to the left to exit the alarm menu and return to the main menu.
 - The cursor shows you which movements are possible and which arrow keys are to be pressed.

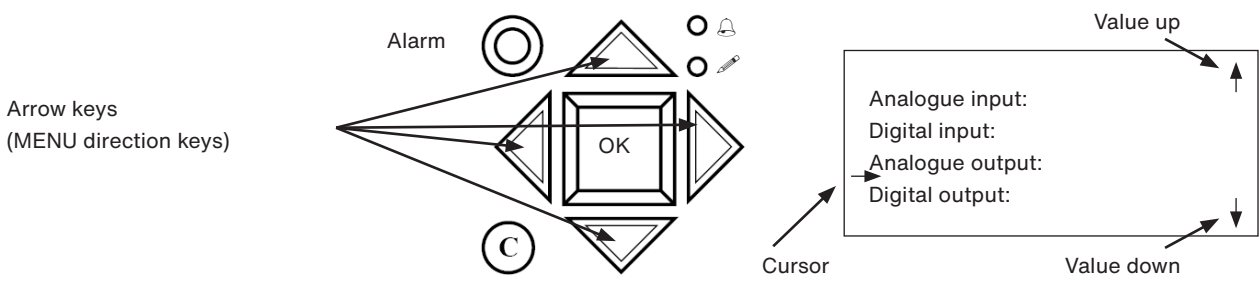

5.2. Configuration example

- Use the cursor to open the desired menu

When this menu opens:

Time: E.g.: **10:33**
 Date: E.g.: **08/12/23 (year/month/day)**
 Day: E.g.: **Tuesday**

Press the OK key.

and enter the password if necessary.

- Enter the desired value using the arrow keys or the numeric keypad.
- To confirm, press the OK key to move to the next field.
- Once all values are updated, press the left arrow key to return to the home page.

5.3. Standard settings (operating menus)

Normal text format = display only / bold formatted text = change possible / bold formatted, underlined text = change possible with password 3333 ... = not used or not accessible.

NOTE: Only parameters formatted in bold may be changed, otherwise any claim to support is forfeited.

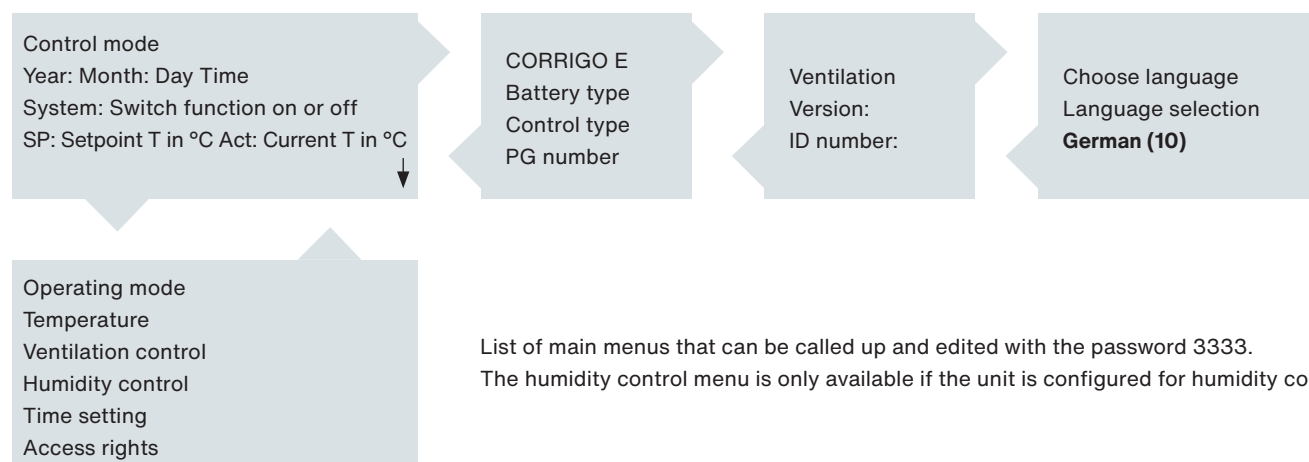

List of main menus that can be called up and edited with the password 3333.
 The humidity control menu is only available if the unit is configured for humidity control.

(10) Language settings (see chapter V.4.e)

5.3.1. Operating mode menu

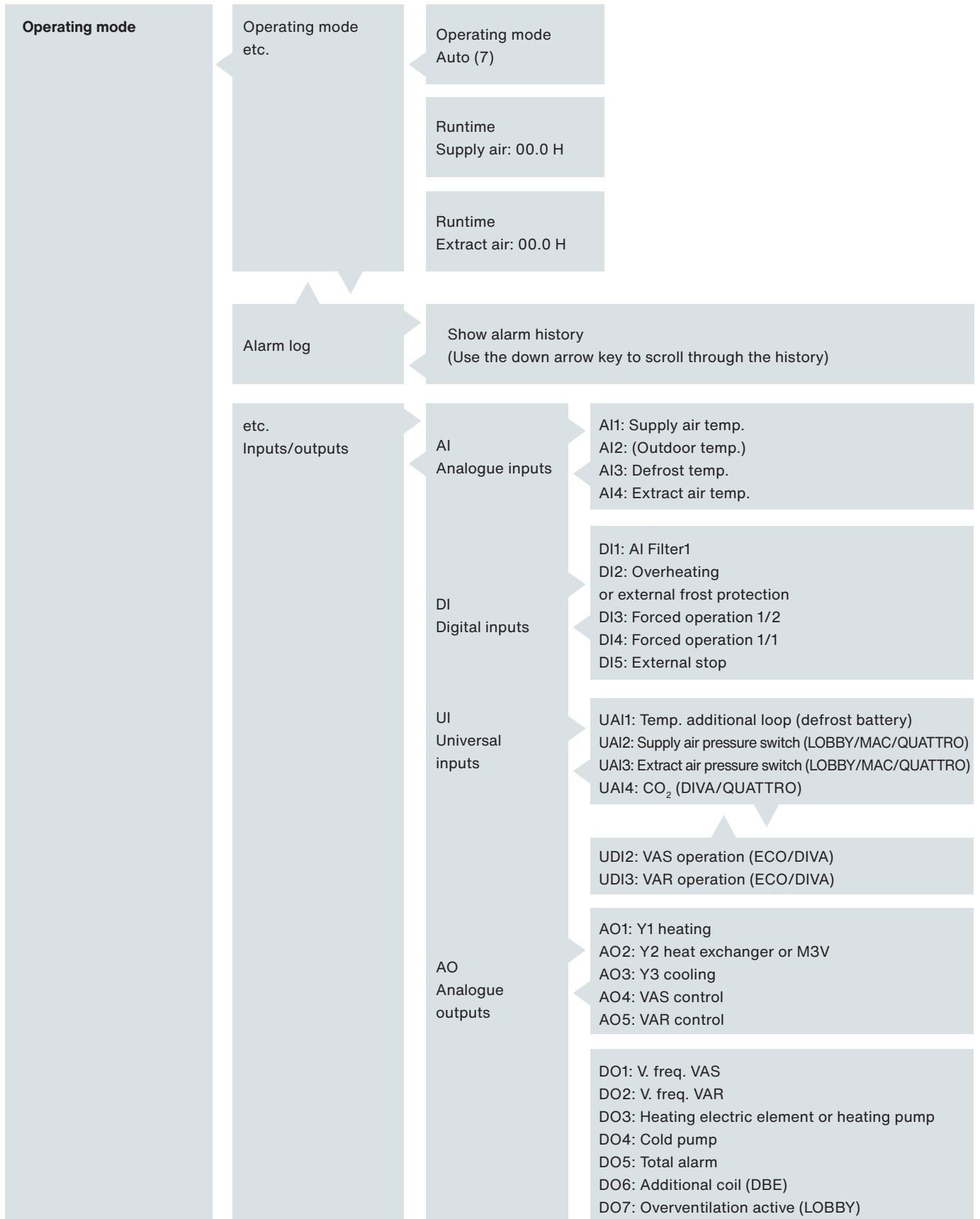

(7) Set on/off operation of the unit (see chapter V.4.d)

5.3.2. Temperature control menu

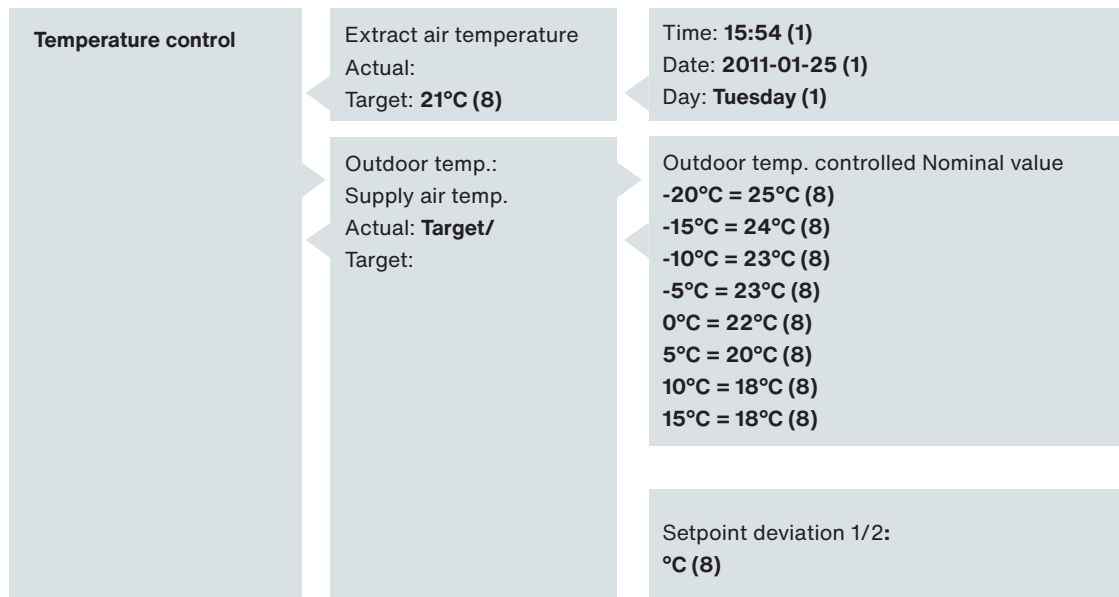

(8) Setting the temperature set point (see chapter V.4.c)

5.3.3. Ventilation control menu

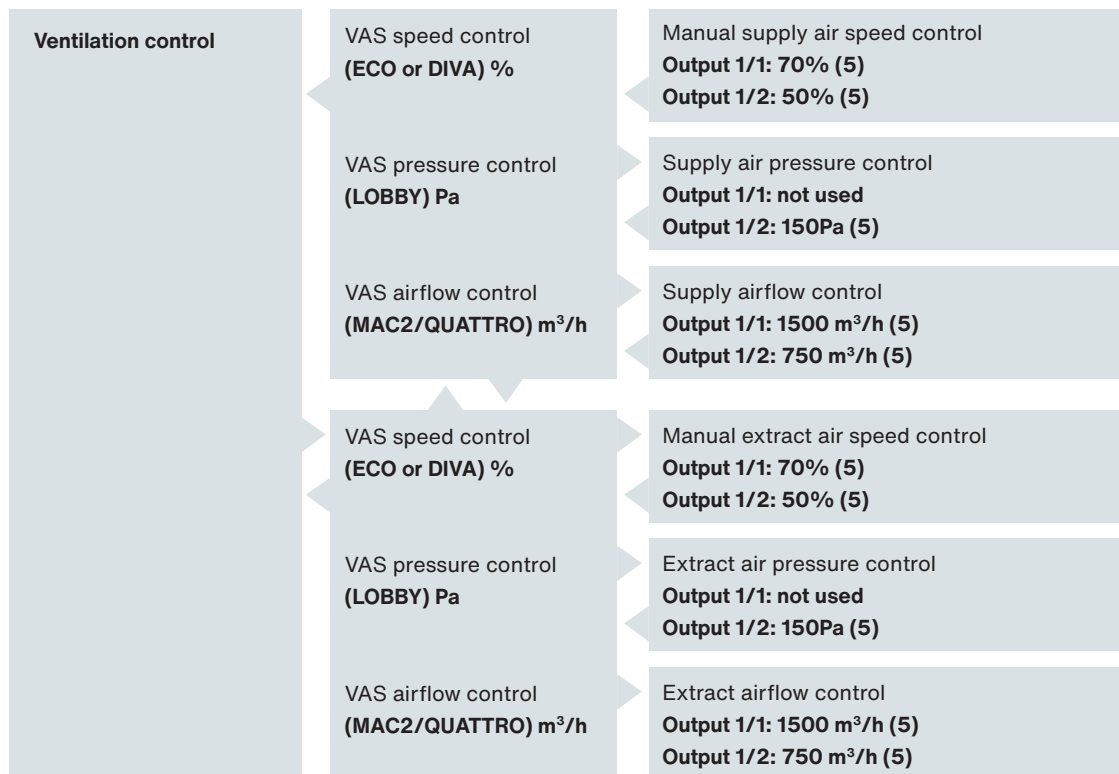

(5) Adjustment of fan speed, pressure and volume flow (see chapter V.4.b)

5.3.4. Time settings menu

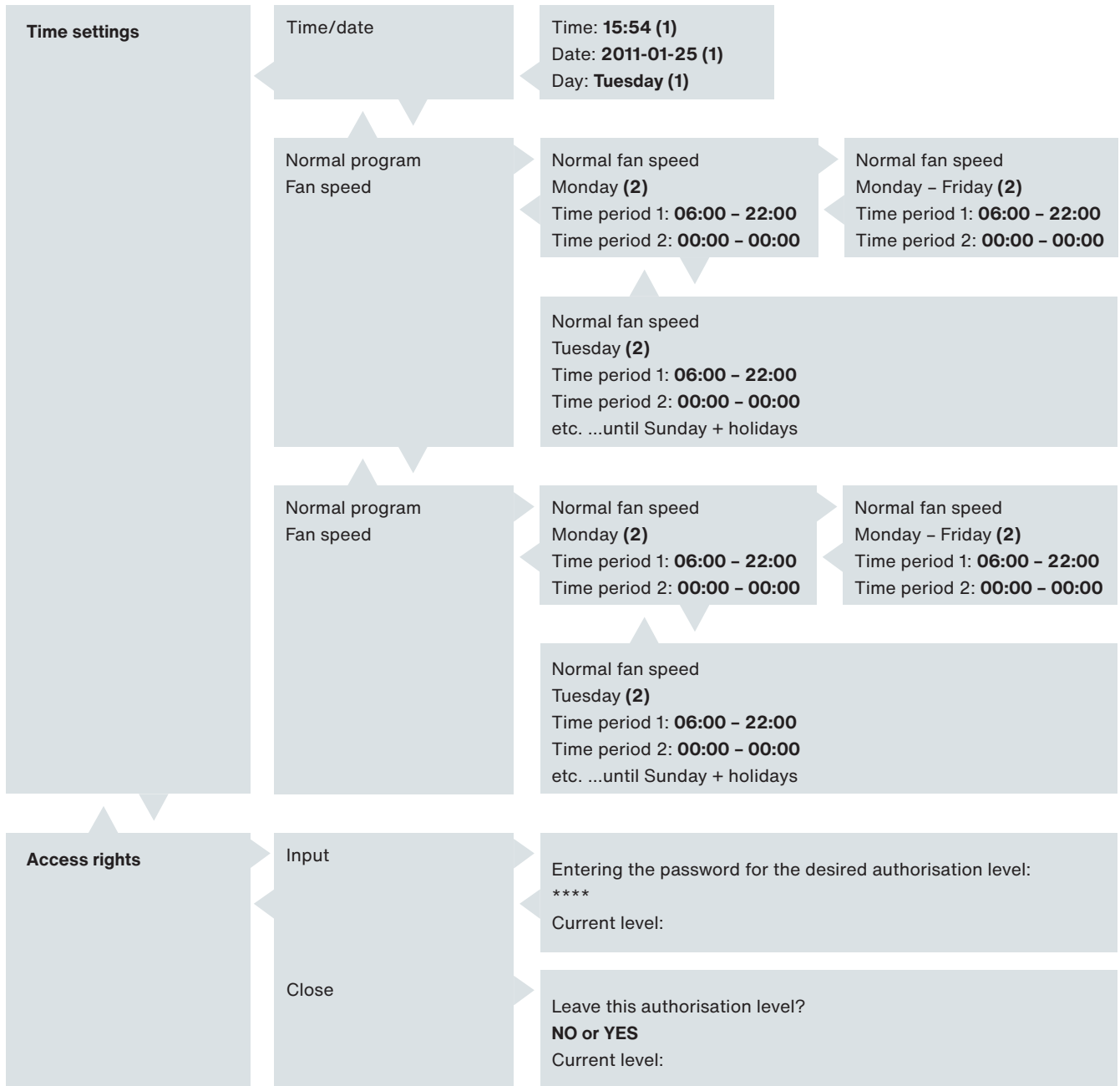

1. Setting the time and date (see chapter V.4.a)
2. Setting the time programme GV (see chapter V.4.a)
3. Setting the time programme PV (see chapter V.4.a)
4. Setting holiday periods (see chapter V.4.a)

5.4. Changing the operator parameters (password 3333 required)

5.4.1. Date and time setting of the timeswitches

Date and time of the CORRIGO controller [(1) chapter V.3.d]

Access: Time setting / Time / Date

The date and time of the controller are preset in CORRIGO. The changeover between summer/winter time is automatic. Setting the operating times of the system [(2) (3) chapter V.3.d]

Access:

- **Normal fan speed programme: Time setting / normal fan speed program**
- **Low fan speed programme: Time setting / low fan speed program**

The system is set to normal fan speed (GV-1/1) from 07:00 to 22:00 and to low fan speed (PV-1/2) from 22:00 to 06:00. Only the **DIVA / LOBBY / QUATTRO** models are permanently set to low fan speed (PV-1/2).

As shown in the tree structure, it is also possible to change the periods from Monday to Friday in the display for Monday by pressing the right arrow key.

Note: If the low fan speed (PV-1/2) and the normal fan speed (GV-1/1) are active in the same time window, the unit runs on GV.

Operational exceptions:



DIVA/QUATTRO: In order for the CO₂ controller to function, no time window with normal fan speed (GV-1/1) may be active.

LOBBY: Only the timeswitch for the low fan speed (PV-1/2) may be active.

NIGHT COOLING: The function is only active when the unit is running at low fan speed (PV-1/1) or is switched off between 00:00 and 07:00. (Example: If the unit is running at low fan speed (PV-1/2) between 02:00 and 06:00 and at normal fan speed (GV-1/1) the rest of the time, NIGHT COOLING can only work from 02:00 to 06:00).

Holiday period [(4) chapter V.3.d] (password 3333 required)

Access: Time setting / holidays

No holiday periods are set in the system. If the runtime is to be shortened during the holiday period, the time settings for holiday operation must be made according to chapter V.3.4 and then the holiday days must be set.

5.4.2. Changing fan speed/pressure, low speed (PV) and high speed (GV)

ECO / DIVA [(5) chapter V.3.c]

Access: Ventilation control / pressure control VAS 1/1 and 1/2 or pressure control VAR 1/1 and 1/2

The fan speed of the unit can be changed in PV-1/2 mode (low speed) and in GV-1/1 mode (normal speed) to control the volume flow for each fan.

- To set the initial volume flow (GV-1/1), set the system to normal fan speed with the “forced switch-on GV” terminals (bridge between terminals 11 and 12).
- To set the initial PV volume flow, set the system to low fan speed with the “Forced switch-on PV” terminals (bridge between terminals 9 and 10).

LOBBY [(5) chapter V.3.c]

Access: Ventilation control / pressure control VAS 1/2 or pressure control VAR 1/2

To adjust the volume flows, change the constant pressure of your unit for each fan.

- To set the initial PV volume flow, set the system to normal fan speed with the “Forced switch-on PV” terminals (bridge between terminals 9 and 10).

MAC2 / QUATTRO [(5) chapter V.3.c]

Access: Ventilation control / airflow control VAS 1/1 and 1/2 or pressure control VAR 1/1 and 1/2

To adjust the volume flows, change the volume flow of your unit for each fan.

- To set the initial volume flow (GV-1/1), set the system to normal fan speed with the “forced switch-on GV” terminals (bridge between terminals 11 and 12).
- To set the initial PV volume flow, set the system to low fan speed with the “Forced switch-on PV” terminals (bridge between terminals 9 and 10).

5.4.3. Changing the temperature setpoint

[(8) chapter 5.3.2]

Access: Temperature control

The setting is based on the control of the following temperatures:

- External temperature controlled supply air temperature (default setting). This means that the supply air temperature setpoint changes depending on the outdoor temperature. This was implemented to align with the EPBD.
- Extract air temperature.

5.4.4. Forced switch-off of the unit or forced switch-on to PV or GV via remote control

[(7) chapter 5.3.1]

Access: Operating mode / Operating mode

It is possible to switch off the unit via the control of the CORRIGO (7) (stop) or to perform a forced switch-on to PV (7). (Manual fan speed 1/2) or GV (7) (manual fan speed 1/1). By default, the unit operates in automatic mode via the timeswitches.

(7) (auto)



When exiting automatic mode, an alarm is displayed. The operating modes Manual fan speed 1/1 and Manual fan speed 1/2 may only be used for commissioning and troubleshooting. Any other setting will inevitably lead to a malfunction of the unit.

5.4.5. Language selection

[(10) chapter 5.3]

Access: Home / Language selection

5.5. Intermediate settings (service level)

Access to the system level configuration menu is required to set the control mode, Night Cooling parameters and CO₂ setpoint. The access right of the “Service” level is required for this. Follow the instructions below:



Use the arrow keys to enter the code 2222 and confirm with the OK key. Press the left arrow key twice to access the menus. In case of an operating error, press the C key twice and repeat the procedure.

5.5.1. Configuration menu at the “Service” access level

Access to the system level configuration menu is required to set the control mode, Night Cooling parameters and CO₂ setpoint. The access right of the “Service” level is required for this. Follow the instructions below:

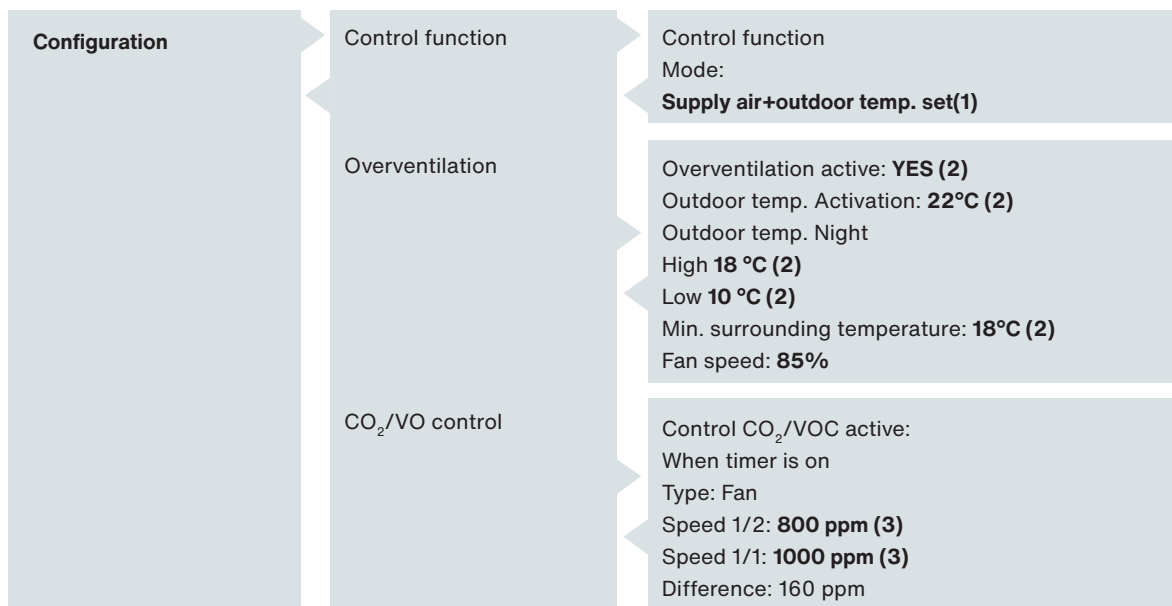

1. Selection of the control mode (see chapter V.6)

2. Changing the Night Cooling settings (see chapter V.6)

3. Changing the CO₂ setpoints (DIVA and QUATTRO only) (see chapter V.6)

5.6. Changing the service parameters (password 2222)

5.6.1. Unit control mode

[(1) chapter 5.5.1]

Access: Configuration / Control function

The control mode of the CORRIGO is set to external temperature controlled supply air control as standard. It is also possible to switch to extract air control mode.



NOTE: If the unit is to be controlled depending on the surrounding temperature, the “extract air control” control mode must be set. Any other choice could cause the unit to malfunction.

5.6.2. Boost ventilation parameters

[(2) chapter 5.5.1]

Access: Configuration / Boost ventilation

The boost ventilation level is set to 85% at the factory. It can be changed. The temperature for switching on the Night Cooling function (daytime outdoor temperature/day) can also be edited and the function can be deactivated.

5.6.3. CO₂ setpoint for DIVA QUATTRO option

[(3) chapter 5.5.1]

Access: Configuration / CO₂/COV control

The CO₂ setpoints are factory set to PV = 800 ppm and GV = 1000 ppm. If a CO₂ concentration of 1000 ppm is reached, the fan speed is increased proportionally until the maximum fan speed is reached.

5.7. Administrator settings

To activate communication, dehumidification and the fire protection function, access to the configuration menu at system level is required. The access right of the “Admin” level is required for this. Follow the instructions below:



Use the arrow keys to enter the code **1111** and confirm with the OK key. Press the left arrow key twice to access the menus. In case of an operating error, press the C key twice and repeat the procedure.

5.7.1. Configuration menu at the “Admin” access level

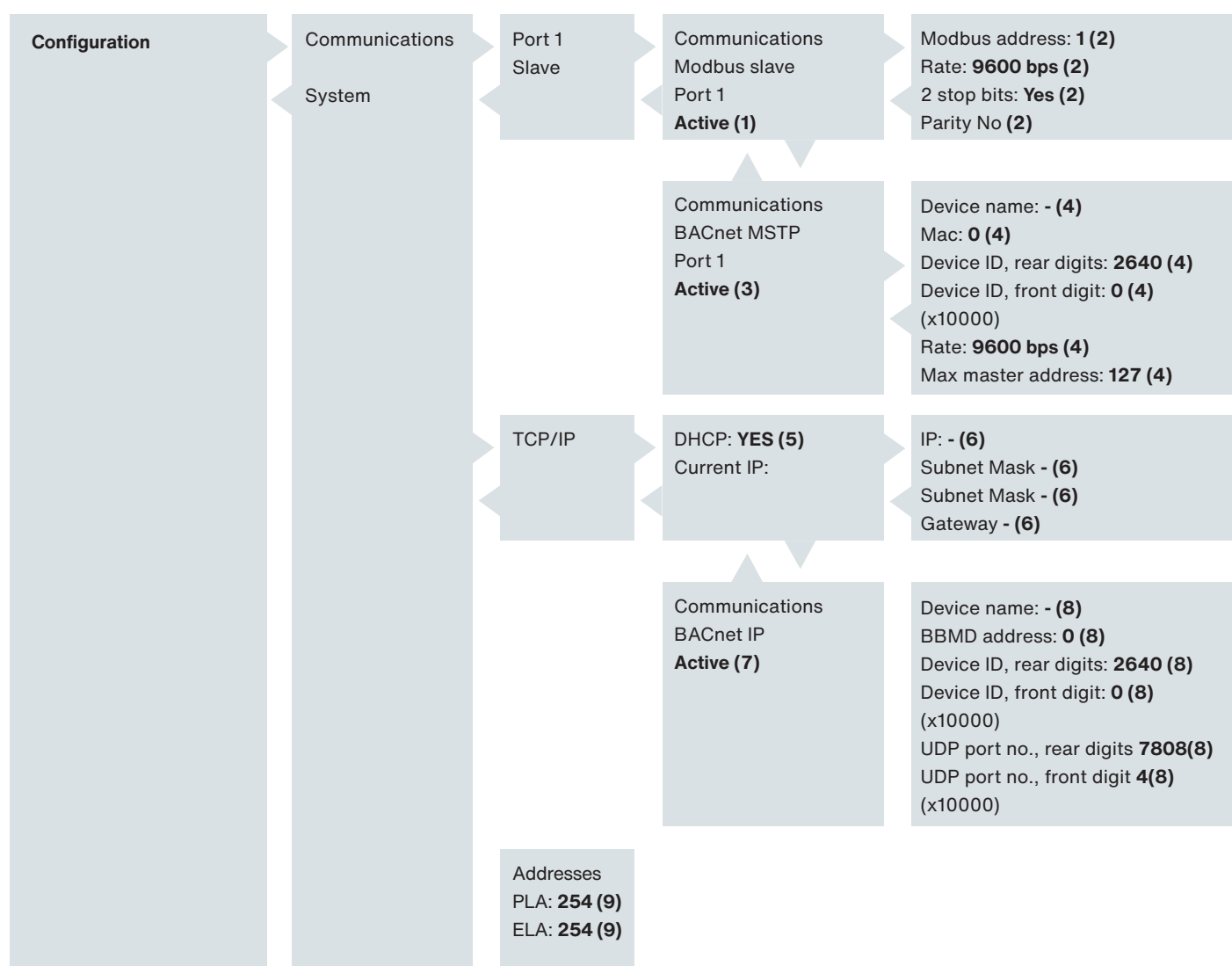

1 and 2 activating the MODBUS RS485 and changing the parameters (see chapter V.8)

3 and 4 activating BACnet MSTP and changing the parameters (see chapter V.8)

5 and 6 changing the TCP/IP address parameters (see chapter V.8)

7 and 8 activating the BACnet IP and changing the parameters (see chapter V.8)

9 addressing the signal amplifier (see chapter V.8)

5.8. Changing the admin parameters (password 1111)

5.8.1. Modbus

The simplified Modbus table can be found at the end of the instructions.

Access: Configuration / Communication

The **MODBUS TCP/IP** is activated in the DHCP by default. To determine the DHCP address or to set the fixed IP address, see [(5)(6) chapter V.7]; the Modbus IP port always remains 502 and the Device ID 255.

The **MODBUS RS485** must be activated [(1) chapter V.7]. Change communication speed, parity and stop bits [(2) chapter V.7].

Modbus type

1 = Coil status register (mode function 1, 5 and 15)

2 = Input status register (mode function 2)

3 = Holding register (mode function 3, 6 and 16)

4 = Input register (mode function 4)

Supported Modbus function

Read Coils (1)

Read discrete input (2)

Read Holding registers (3)

Read Input registers (4)

Write single Coils (5)

Write single register (6)

Write multiple Coils (15)

Write multiple register (16)

EXOL type

R = Real (-3.3E38 – 3.3E38)

I = Integer (-32768 – 32767)

X = Index (0 – 255)

L = Logic (0/1)

Transmission mode

The controller uses the RTU transmission mode.

A maximum of 47 registers can be read in a single message.

The Modbus must wait at least 3.5 times for a character (4 ms at 9600 bps) between two messages. It is limited to 10 fast data transmissions every 30 seconds; the other data transmissions have a response time of about 1 s.

For all signals of the real number type (with floating point), the scaling factor 10 applies; except for the signals for time settings with the scaling factor 100 and the signals for the air volume with the scaling factor 1. The scaling factor 1 applies to the signals for integers, indices and Boolean values.

5.8.2. Signal amplifier

[(3) chapter 5.6.1]

Access: Configuration / System

An operating manual is enclosed with each signal amplifier. If several CORRIGO controllers are linked to one remote control (up to 6 CORRIGO controllers), the PLA/ELA address of each CORRIGO controller must be changed. In this case, each CORRIGO must be assigned a separate address, which must be entered precisely into the signal amplifier. For the operation of the signal amplifier and the setting of the signal amplifier addresses, the operating instructions enclosed with the signal amplifier must be followed.

5.8.3. Internet communication

[(5) (6) chapter 5.6.1]

The web page is already loaded and the controller is set to the DHCP.

To determine the DHCP address or to set the fixed IP address, see [(5)(6) chapter V.7] or via the download of the E-Tool software <http://www.regin.se> (Download tab).

5.8.4. BACnet

The simplified BACnet table can be found at the end of the instructions.

Access: Configuration / Communication

The **BACnet IP** must be activated [(7) chapter V.7]. To determine the DHCP address or to set the fixed IP address, see [(5) (6) chapter V.7]. To set the Port No. ID, see [(8) chapter V.7].

The **BACnet MSTP** must be activated [(3) chapter V.7]. To change the data transmission speed, ID, address, etc., see [(4) chapter V.7]. Rate = 9600 / MAC Address = 0 / Device ID = 2640 / Max. Master = 127

BACnet type

10XXXX = Read and write Binary

20XXXX = Read binary

30XXXX = Read and write analog

40XXXX = Read analog

30XXXX = Read and write multistate

AV = Analogue value

40XXXX = Read multistate

BV = Binary value

(XXX = MODBUS address)

MSV = Multistate value

BMMD address: The BMMD address is used to detect units that are connected to different BACnet/IP subnets and separated by an IP router. The address is entered as "Host": Here, "Host" can be the host name if the DNS is configured. If the DNS is not configured, the host address should be entered in the format xxx.xxx.xxx followed by the port number (default 47808).

MAC: The MAC address of the unit. This only has to be unique for the subnet.

Device ID: Device identifier for identifying the device in the BACnet network. This number may not be duplicated in the BACnet network, i.e. it must be unique. To set an ID value of 34600, the back digits would be set to 4600 and the front digit to 3. For more information, see the CORRIGO PICS via <http://www.regin.se>

5.8.5. LON communication (for CORRIGO with LON option)

The LON function is set as follows:

In the Configuration menu / Communication / Function Port 2 = Activate the function Port 2 in the extension unit.

On the right-hand side, register extension unit 1 under CORRIGO E28 LON.

The key for the service PIN is located on the back of the controller.

The communication table can be found at <http://www.regincontrols.com>.

5.8.6. Activating the fire protection function

Input configuration

Access: Configuration / Input Output / DI / DI8

Register input DI8 as "Fire alarm" "NO".

Function configuration

Access: Configuration / Fire protection function

Select the desired mode when activating the fire protection function.

"Stop": Complete switch-off of the unit.

"Permanent operation": Commissioning or operation of the unit on GV. The fire protection function has priority over all other alarms.

"Normal operation": Operation of the unit depending on the configuration at the place of use (Stop/PV/GV).

"Supply fan only": Commissioning or operation of the supply fan on GV (extract air off)

"Extract fan only": Commissioning or operation of the extract fan on GV (supply air off).

Alarm configuration

Access: Configuration / Alarm configuration

Enter the alarm number "10". On the right-hand side, enter "Active" as priority "Alarm C".

5.8.7. Activating the dehumidification function

Input configuration

Access: Configuration / Input Output / UI / UI4

Register input UI4 as "Room humidity".

Function configuration

Access: Configuration / Humidity control

Select "Dehumidification"

Setpoint adjustment

Access: Humidity control

Enter the desired setpoint.

6. Troubleshooting

6.1. Error types

The EASY controller is equipped with alarms. When the red LED flashes, press the alarm key (red) to indicate the error. It is a class A or C error (see below).

Error type:

A: The error causes the ventilation system to stop. The unit cannot be put back into operation until the problem has been corrected and the error has been acknowledged.

C: The error does not stop the ventilation system. It will be automatically deleted as soon as the problem is solved.

To acknowledge an error, press the alarm key (red), "Cancel" and then "Save" the error with the arrow keys and the OK key. Attention: do not "block".

Description	Cause
The CORRIGO display does not switch on.	<ul style="list-style-type: none"> - The unit is not powered properly (CORRIGO P/B LED off). - Press a key to switch on the display (backlight). - The control fuses are out of service.
The fan or fans are not working.	<ul style="list-style-type: none"> - The timeswitches are set to 0. - No external start command - External shutdown - Active alarm
The remote control does not work or displays incorrect values.	<ul style="list-style-type: none"> Remote control cable longer than 100 m Signal amplifier incorrectly connected

6.2. Alarm directory

No.	Display	Description	Type	Time	Cause
1	VAS error	(UDI2 must be closed ("ON") while the fan is running.) or UAI2 must be above 30 Pa while the fan is running.)	A	30s (120s at LOBBY)	The pressure switch is connected incorrectly (pressure switch must be set to 25Pa). The pressure detected by the measuring transducer is less than 25 Pa. (LOBBY) (Contact us.) The motor is out of operation. The thermal motor protection has been triggered. Check the connections of the transparent pipes (chapters IV.8 and IV.9). Water in the transparent tube. 0-10 V motor inverted.
2	VAR error	(UDI3 must be closed ("ON") while the fan is running.) or UAI3 must be above 30 Pa while the fan is running.)	A	30s (120s at LOBBY)	The pressure switch is connected incorrectly (pressure switch must be set to 25Pa). The pressure detected by the measuring transducer is less than 25 Pa. (LOBBY) (Contact us.) The motor is out of operation. The thermal motor protection has been triggered. Check the connections of the transparent pipes (chapters IV.8 and IV.9). Water in the transparent tube. 0-10 V motor inverted.
6	Filter dirty	DI1 must be open ("OFF") if there is no error.	C	5s	The filter(s) are dirty. The filter pressure switch(es) are connected incorrectly (the pressure switches must be set to 300 Pa for M5+M7). Check the connections of the transparent pipes (chapter IV.8).
8	External frost protection	Ext DI2 must be closed ("ON") if there is no error.	C	120s	The thermostat THA is not set to 5°C. The thermostat THA is out of operation. The circulation pump is out of operation. The 3-way valve is incorrectly wired, incorrectly connected hydraulically or out of service.
15	High supply air temperature	Ext AI1 has risen to over 50°C.	A	30s	The supply air temperature has exceeded 50°C. The temperature setpoint is too high. The supply fan has switched off (VAS error) although the heating coil was fully charged.
23	Overheating of electrical battery	Ext DI2 must be closed ("ON") if there is no error.	A	5s	The safety thermostat THS has been triggered. To reset the THS, press the reset key on the electrical battery. Power failure The supply fan has switched off (VAS error) although the electrical battery was fully charged.
27	External temp. sensor error	Check value at Ext. AI2.	A	5s	The external temperature sensor SEG is out of operation. The external temperature sensor SEG is wired incorrectly (see chapter IV.3).

No.	Display	Description	Type	Time	Cause
31	VAS pressure error	More than 50 Pa deviation between supply air setpoint and pressure measured at Ext. UAI1	C	30min	The supply air network does not correspond to the selected fan or the pressure setpoint. The filter is dirty.
32	VAR pressure error	More than 50 Pa deviation between setpoint and exhaust pressure measured at Ext UAI2	C	30min	The extract air network does not correspond to the selected fan or the pressure setpoint. The filter is dirty.
35	Manual	Operation in manual mode	C	5s	Error message for information (the unit was stopped directly on the display or switched to PV or GV (see (7) chapter V.3.a).
36 to 44	...in manual mode	Functions have been changed to manual mode.	C	5s	In the Manual/Auto menu, everything must be set to Auto.
48	Battery weak	Internal battery error	A	5s	The internal battery of the CORRIGO is out of service. Change the battery immediately so that the programming is not lost. See chapter VII.2
49	AS-temp. sensor error	Check value at Ext. AI1.	A	5s	The supply air temperature sensor SSG is out of operation. The supply air temperature sensor SSG is wired incorrectly (see chapter V.3.a).
50	AR-temp. sensor error	Check value at Ext. AI3.	A	5s	The extract air temperature sensor SRG is out of operation. The extract air temperature sensor SRG is wired incorrectly (see chapter V.3.a).
55	VAS pressure sensor error	Check value at Ext. UAI1.	A	5s	The 0-10 V signal is inverted. Short circuit at the supply air pressure transducer.
56	VAR pressure sensor error	Check value at Ext. UAI2.	A	5s	The 0-10 V signal is inverted. Short circuit on the extract air pressure transducer.
59	Fault on the CO₂ sensor	Check value at Ext. AI4.	A	5s	The 0-10 V signal is inverted. Electrical short circuit on the CO ₂ sensor.
85	...in manual mode	Functions have been changed to manual mode.	A	5s	In the Manual/Auto menu, everything must be set to Auto.
86	Perform maintenance	Regular maintenance	C	5s	See chapter VI.3
87	...in manual mode	Functions have been changed to manual mode.	C	5s	In the Manual/Auto menu, everything must be set to Auto.

6.3. Acknowledgement of the “Perform maintenance” error

Access to the “Settings” menu is required for this configuration. The access right of the “Service” level is required for this.

Follow the instructions below:



Use the arrow keys to enter the code 2222 and confirm with the OK key. Press the left arrow key twice to access the menus. In case of an operating error, press the C key twice and repeat the procedure.

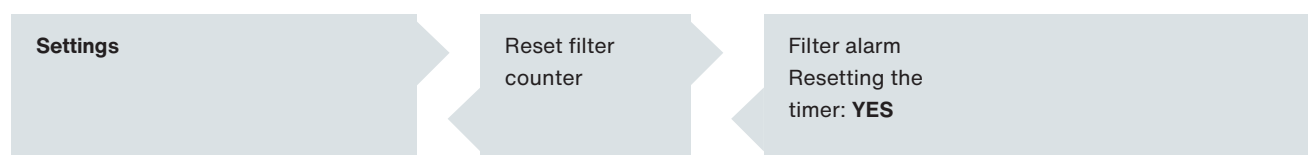

An alarm appears every 6 months to indicate that maintenance is due. Enter YES to reset the meter.

7. Maintenance

7.1. Mandatory maintenance

External components of the unit

Check the ducts, canvas connectors and vibration dampers and replace them if necessary. Ensure that no vibrations can be transmitted to the external components by the elements connected to the unit.

Unit and controller

Check connections annually.

Air filtration

*Do not damage the filters.

Classification	Max. pressure drop	Filter efficiency class	Reference	Washing* Blow cleaning*	Aspiration* Exhaust*
Gravimetric	Gravimetric	ePM10 50% (M5)	M5	Limited (1 to 4 times)	YES
Opacimetric	Opacimetric	ePM1 55% (F7)	F7	NO	

Components	Maintenance interval			
	1 MONTH	3 MONTHS	6 MONTHS	12 MONTHS
Filter	Blow cleaning (M5 filter)	Washing (M5 filter)	Replace filter if necessary	Mandatory filter replacement

7.2. Alarm directory

If the low battery alarm appears and the red lamp glows, the reserve battery to back up the memory and the real-time timeswitch is too low. The procedure for replacing the battery is described below. The operation of the timeswitch is secured by a condenser so that it can continue to run for about 10 minutes after an interruption in the power supply. If the battery change takes less than 10 minutes, the program does not need to be reloaded, and the timeswitch continues to run normally.

The replacement battery is a CR2032 type battery.



Using a small screwdriver, press the clips down on both sides of the housing and detach the cover from the base mount. Hold the base mount and remove the lid.

Inserting the battery

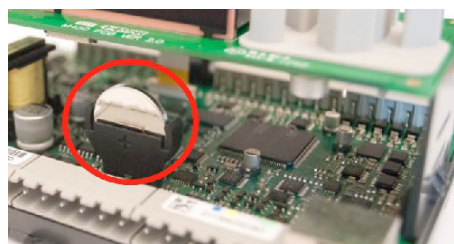

Take hold of the battery and carefully pull it out upwards.

Push the new battery into the base mount and press it in firmly. Note: Pay attention to the correct polarity of the battery!

8. Annexes

8.1. Control circuit diagram

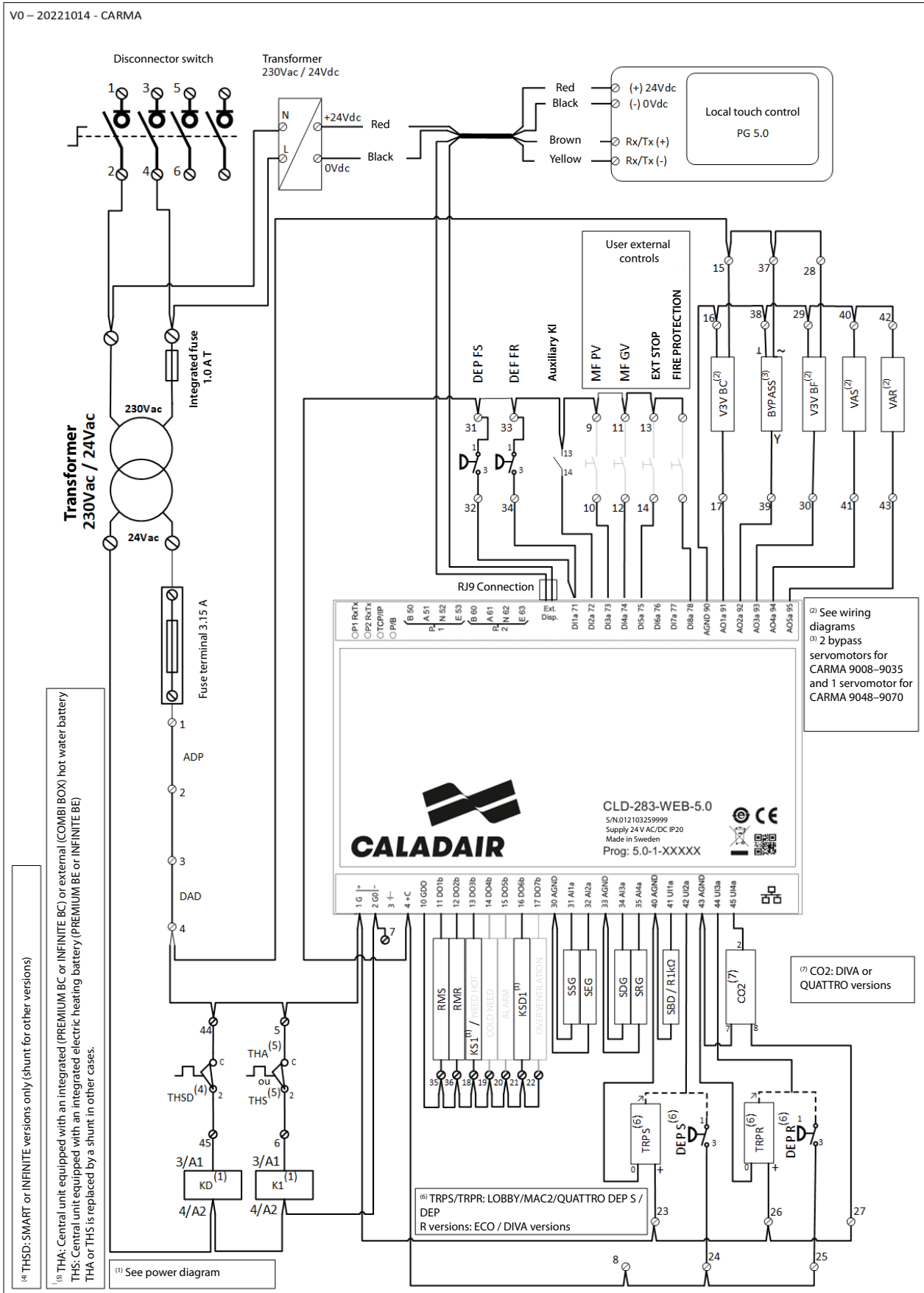

8.2. Control circuit diagram

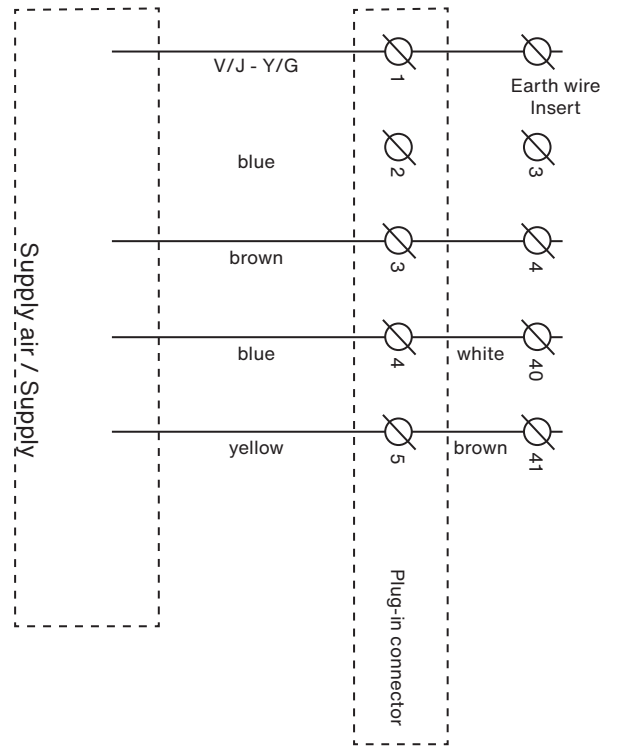
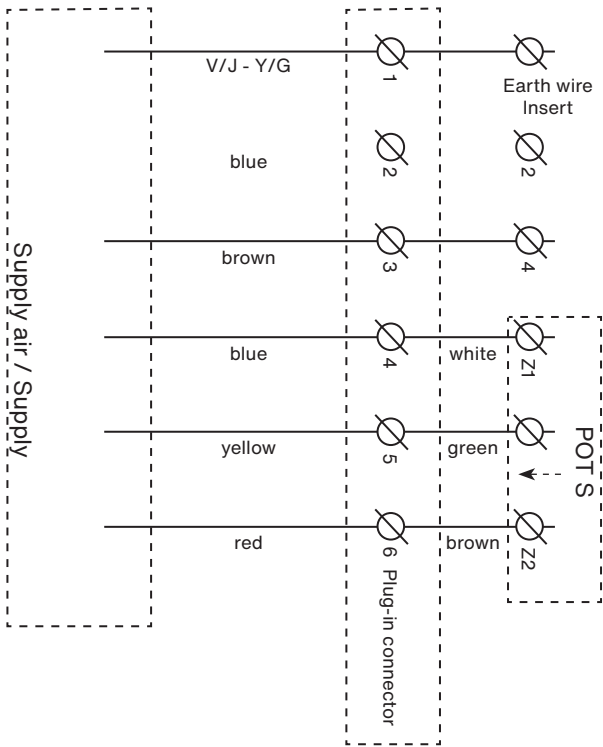

SEASON

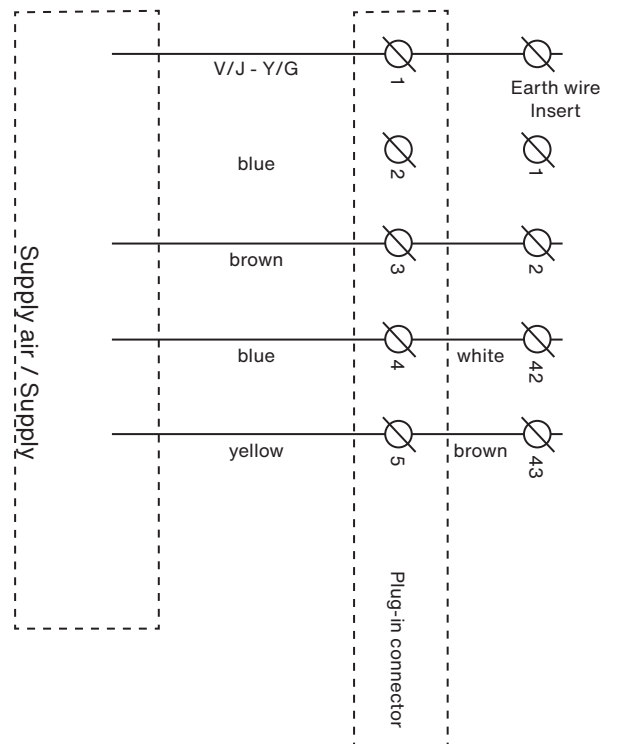
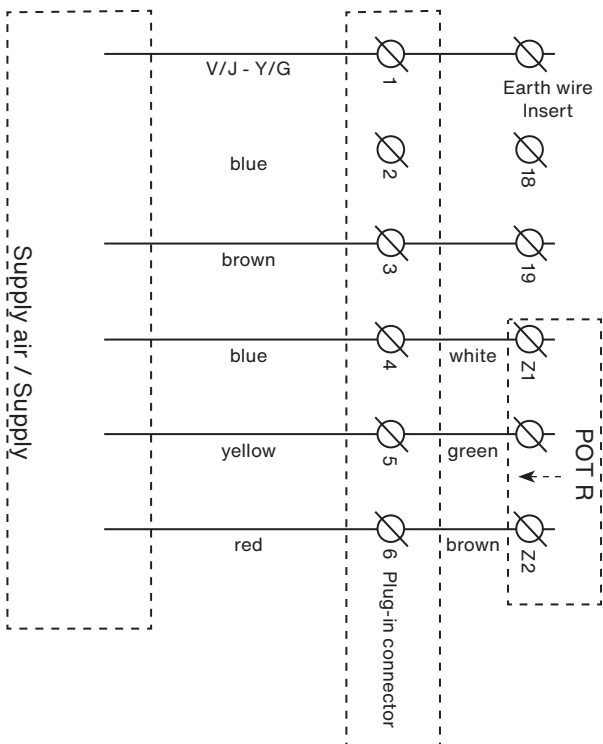

8.3. Connection of the Zehnder Neotime 1300-1800-2500 motors

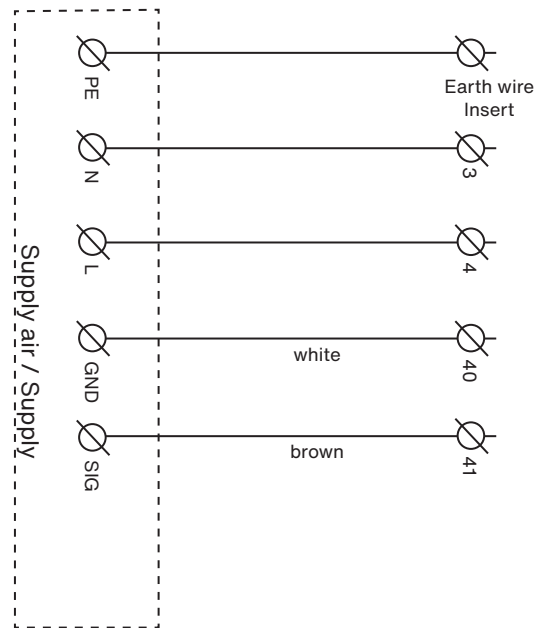
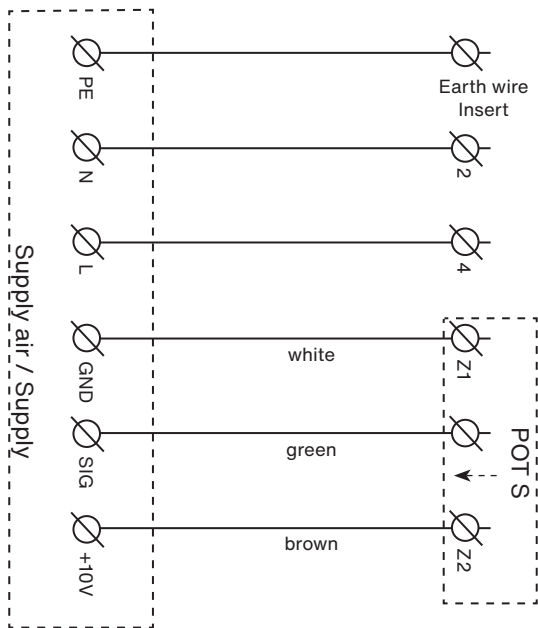

SEASON

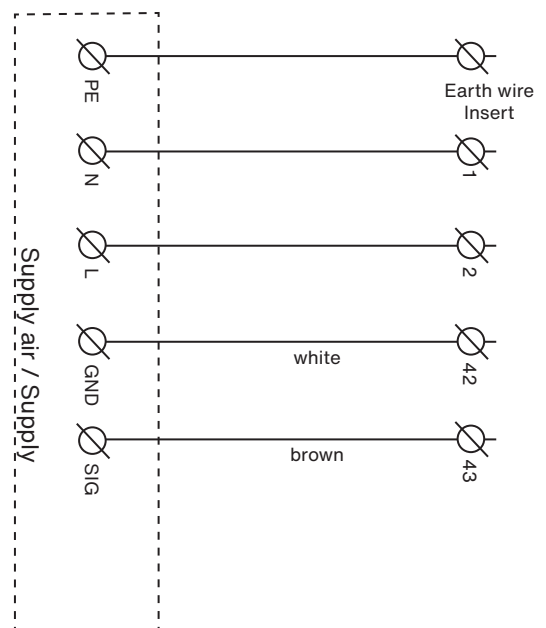
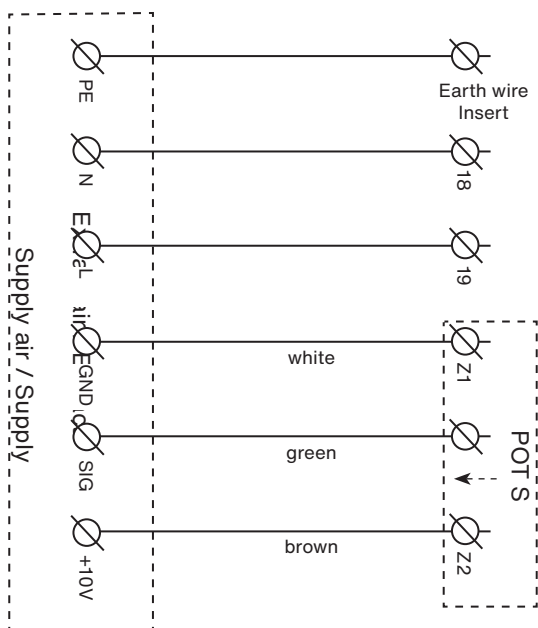

8.4. Connection of the Zehnder Carma 9008 motors

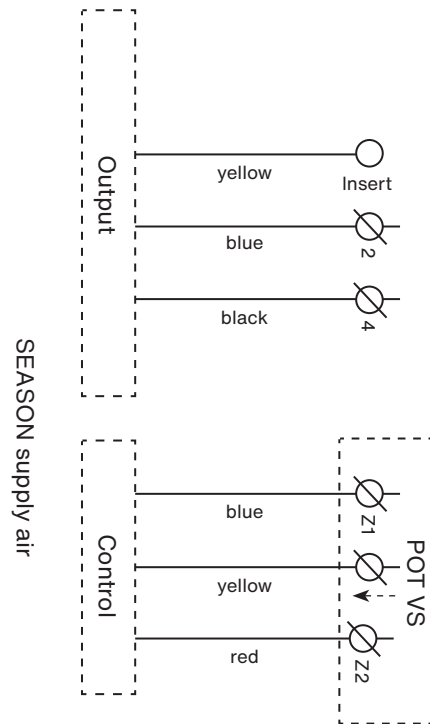
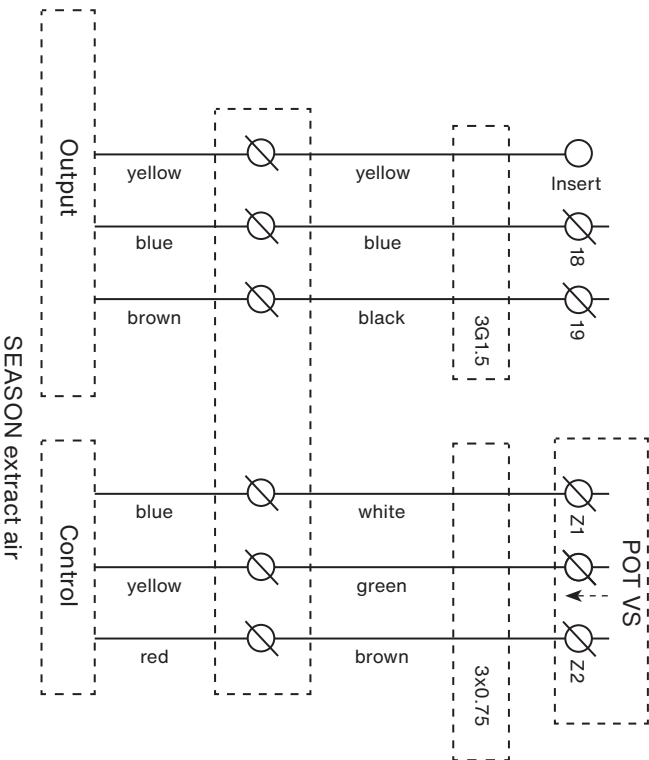
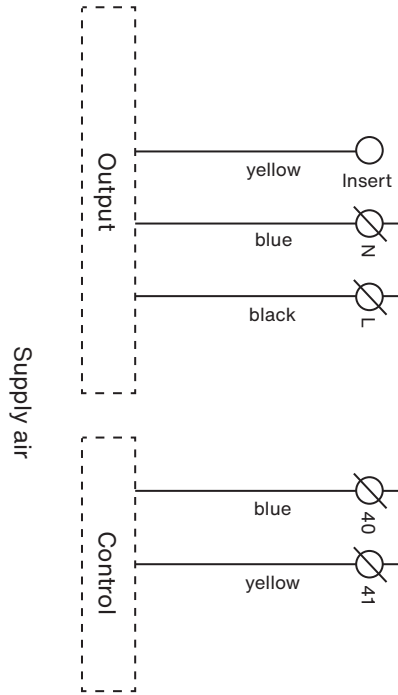
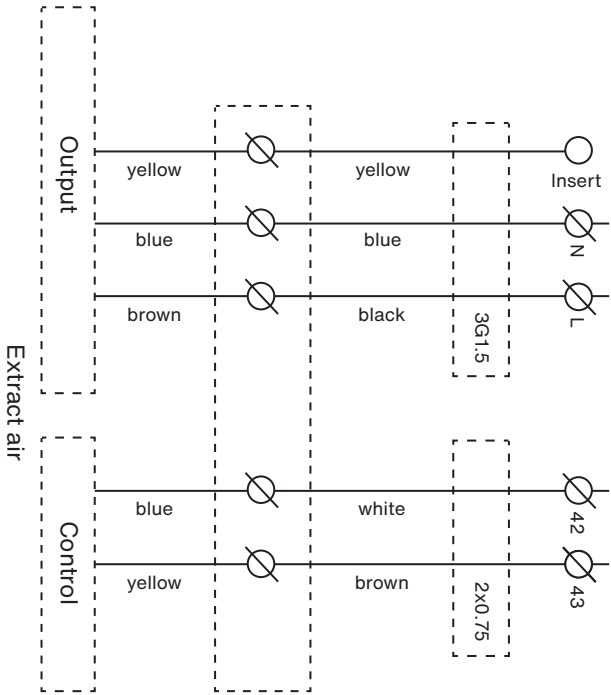

8.5. Connection of the Zehnder Carma 9010-9070 motors

Carma 9010, 9016, 9023 SEASON

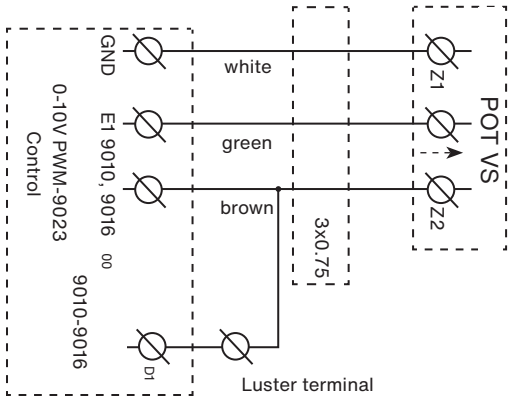
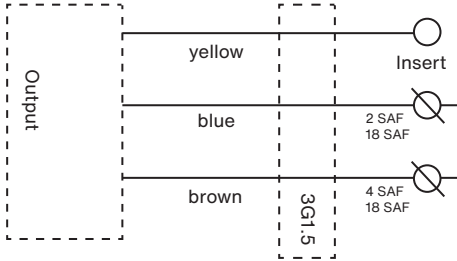

Carma 9010, 9016, 9023 EVERKIT 1500

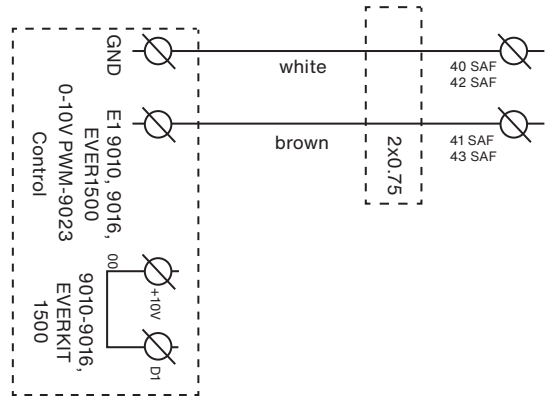
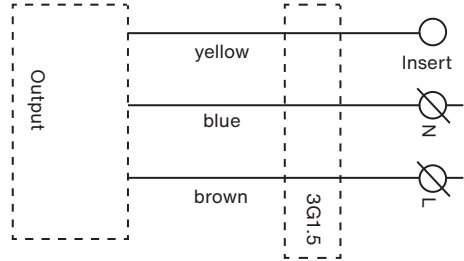

Carma 9035, 9048, 9070 SEASON

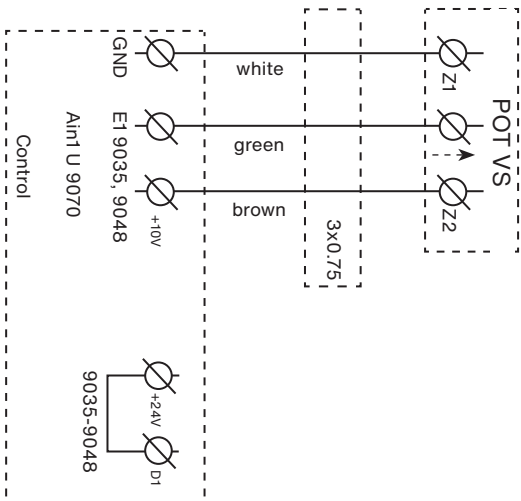
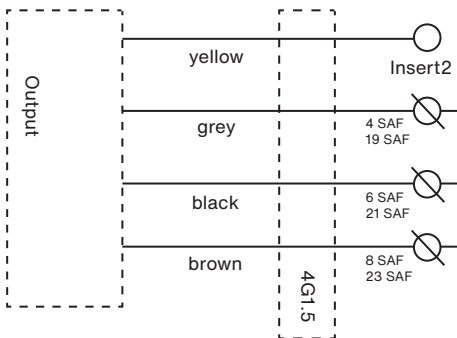

Carma 9035, 9048, 9070 EVERKIT 3000 / EVERKIT 5000

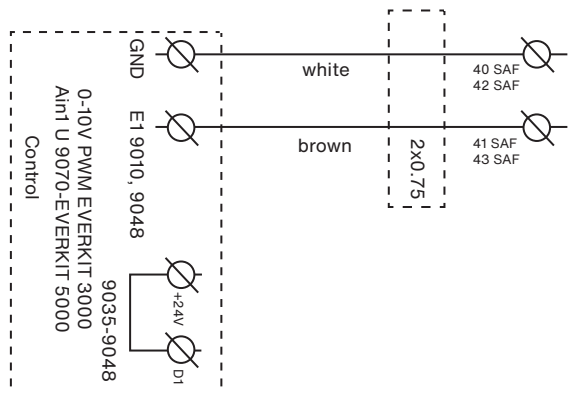
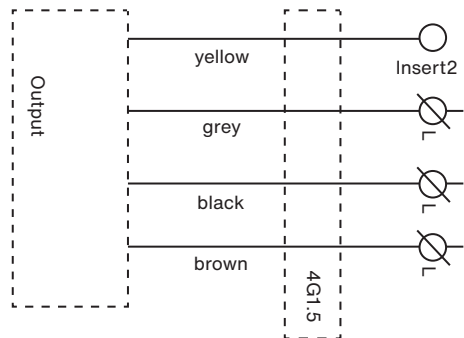

8.6. Zehnder Neotime performance graphs Zehnder Neotime 600

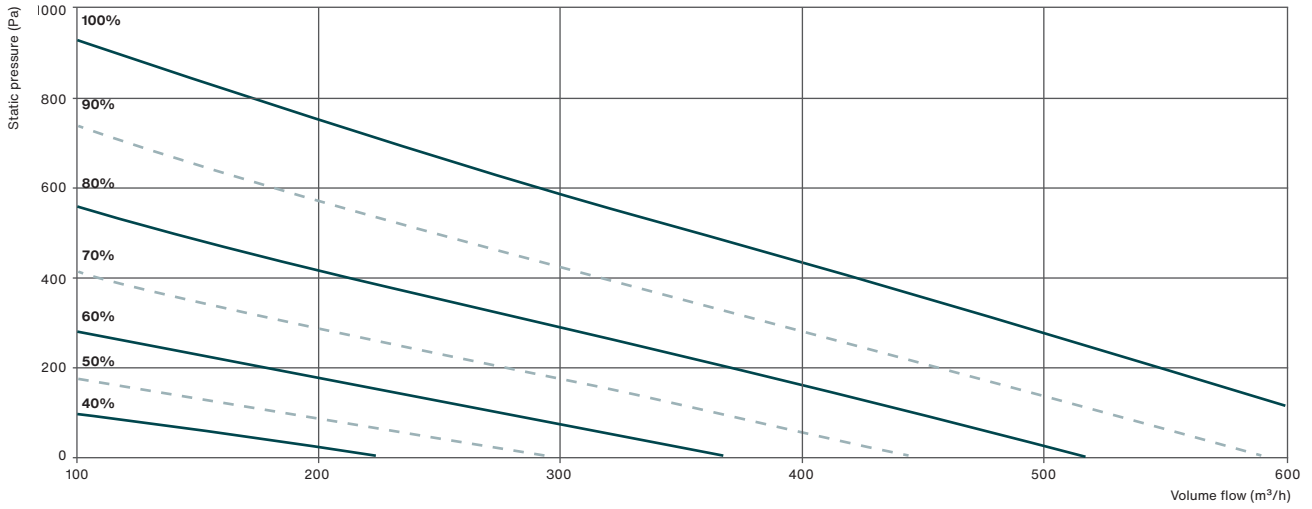

Zehnder Neotime 900

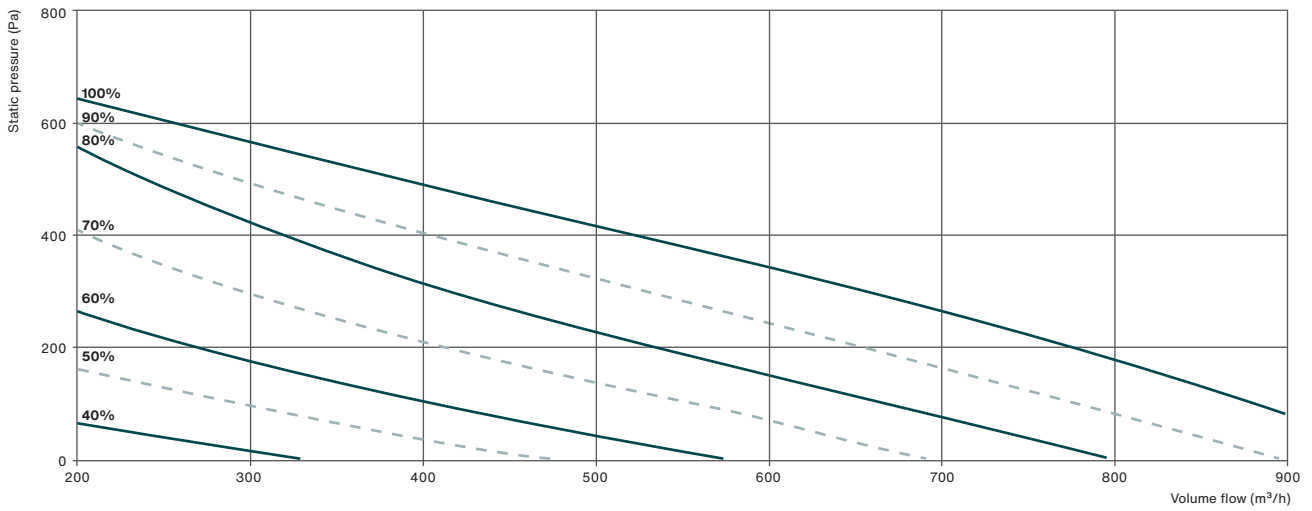

Zehnder Neotime 1300

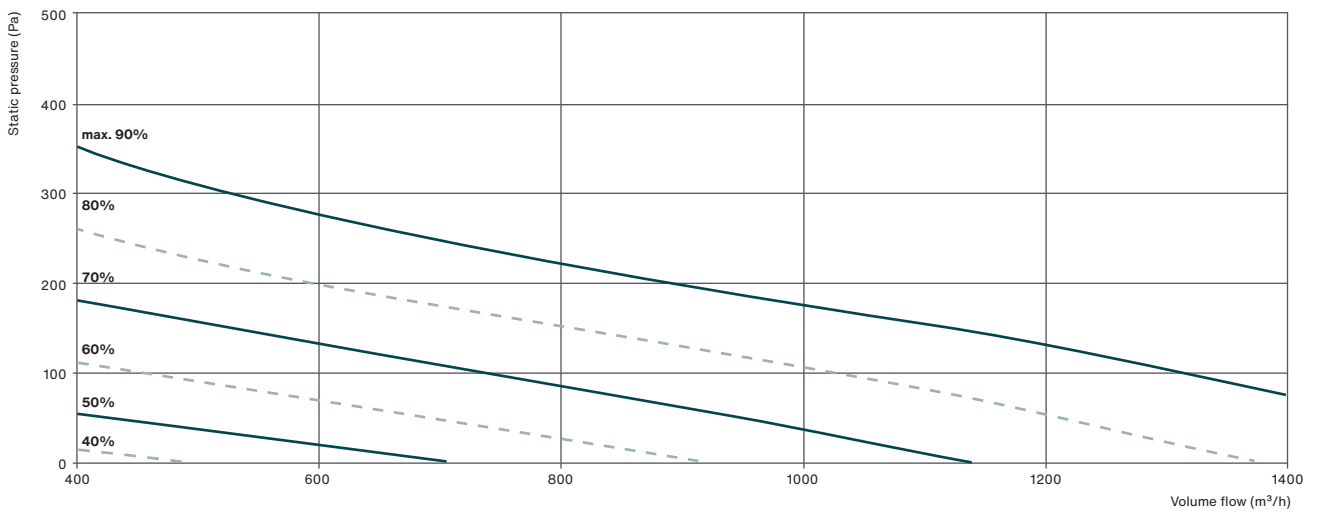

Zehnder Neotime 1800

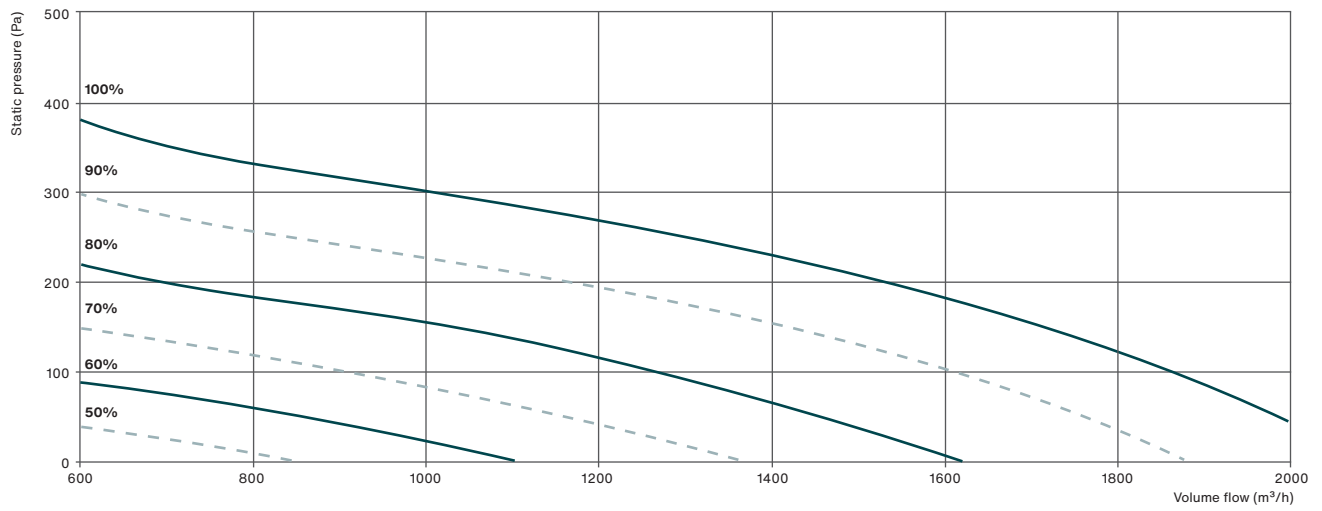

Zehnder Neotime 2500

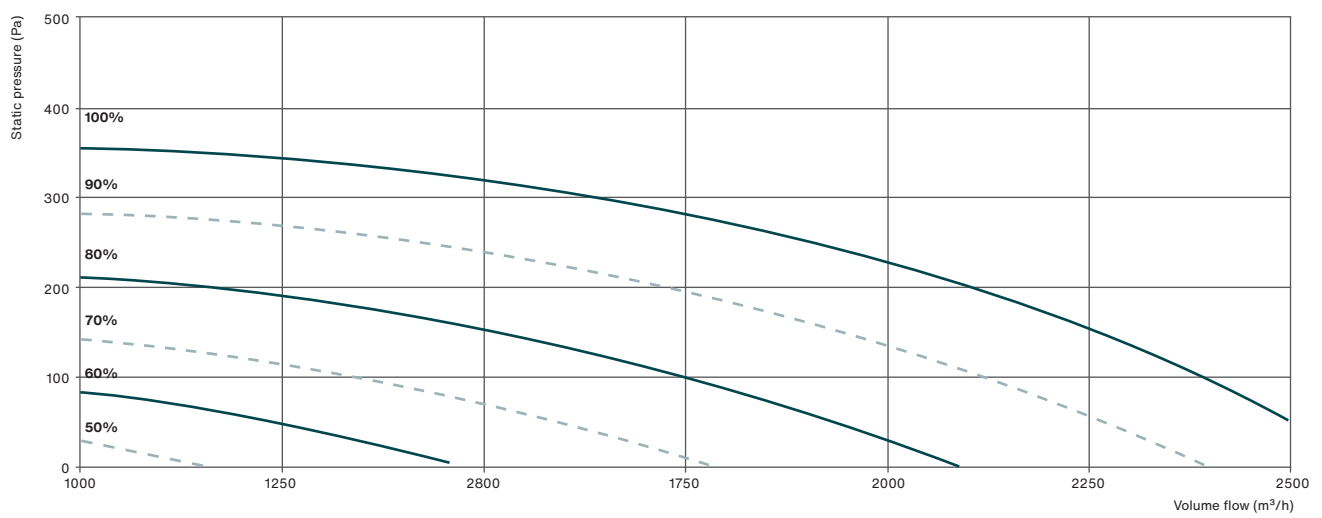

8.7. Zehnder Carma performance graphs
Zehnder Carma 9008

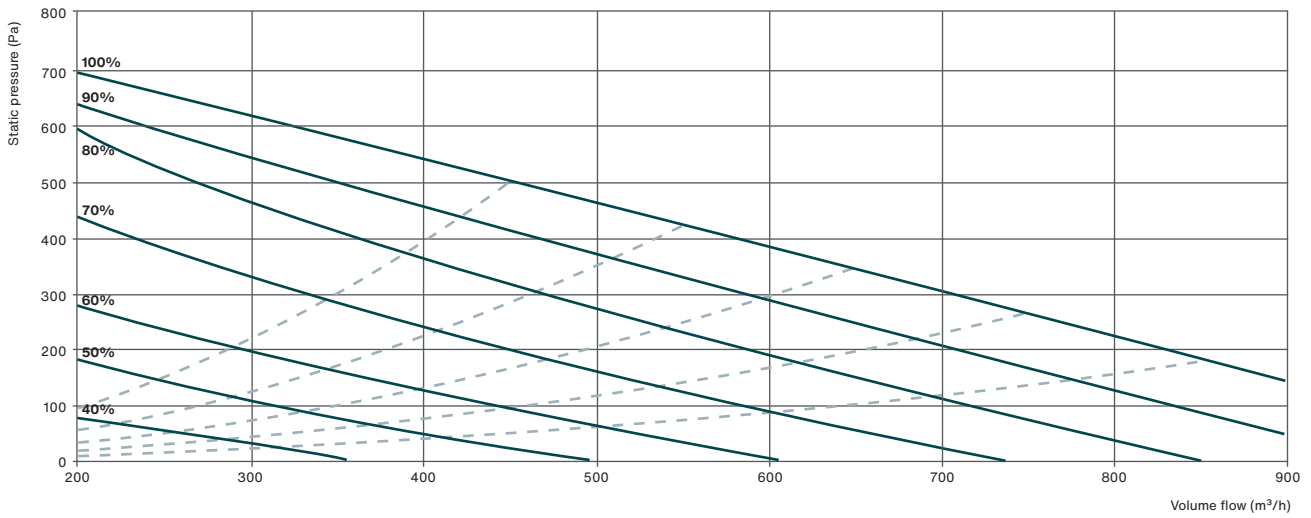

Zehnder Carma 9010

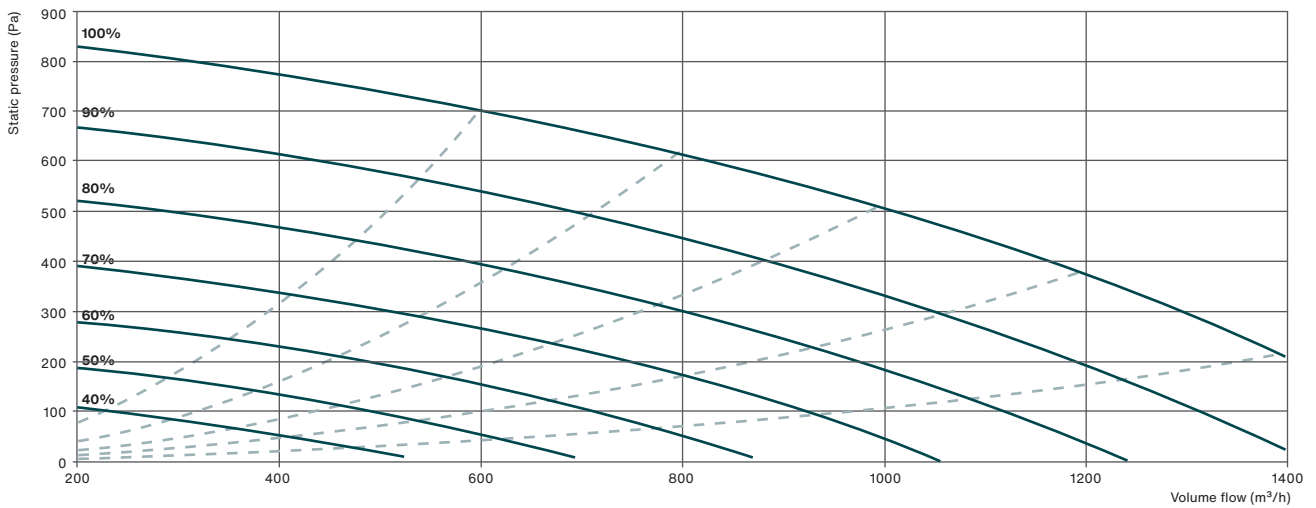

Zehnder Carma 9016

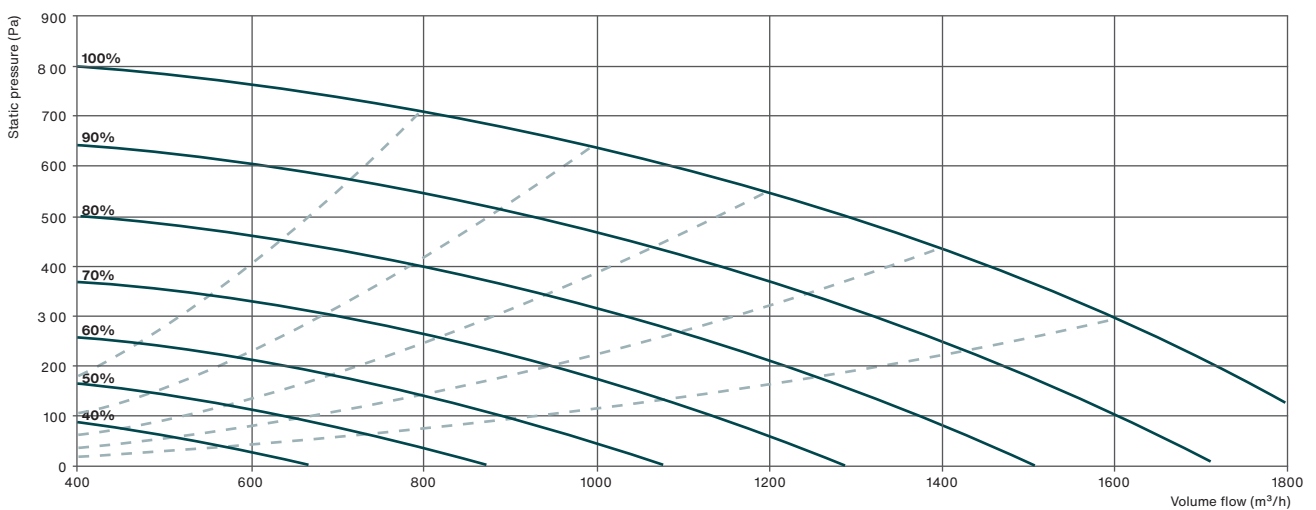

Zehnder Carma 9023

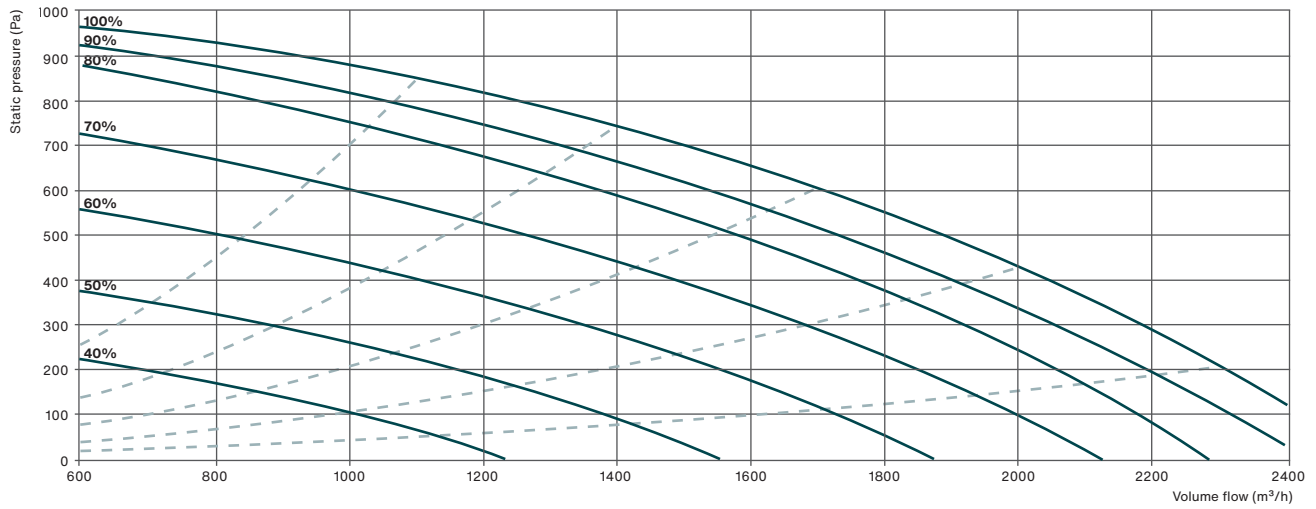

Zehnder Carma 9035

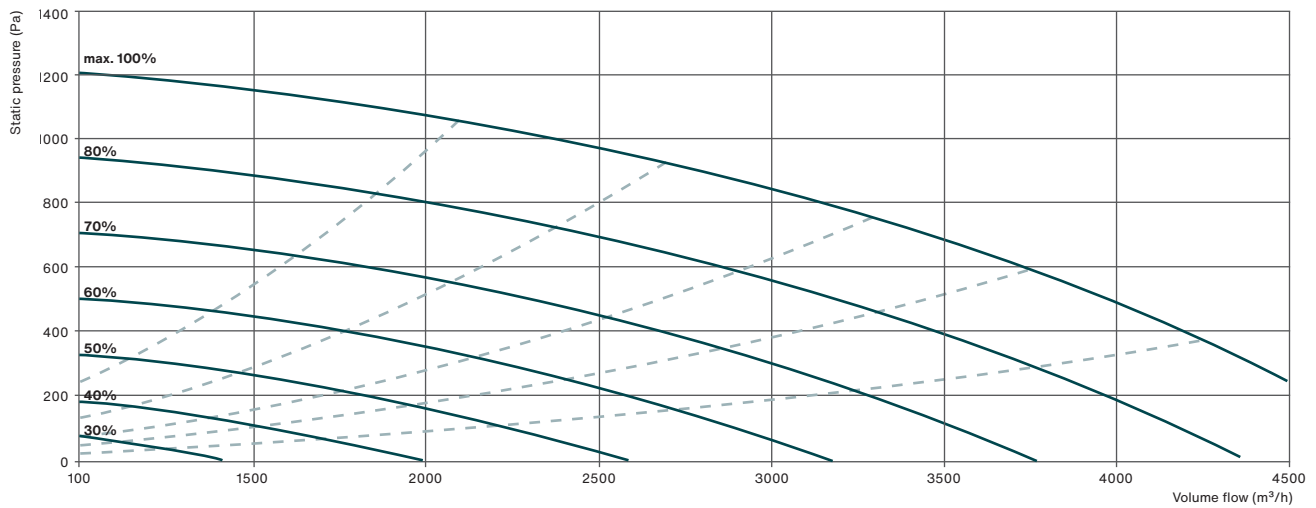

Zehnder Carma 9048

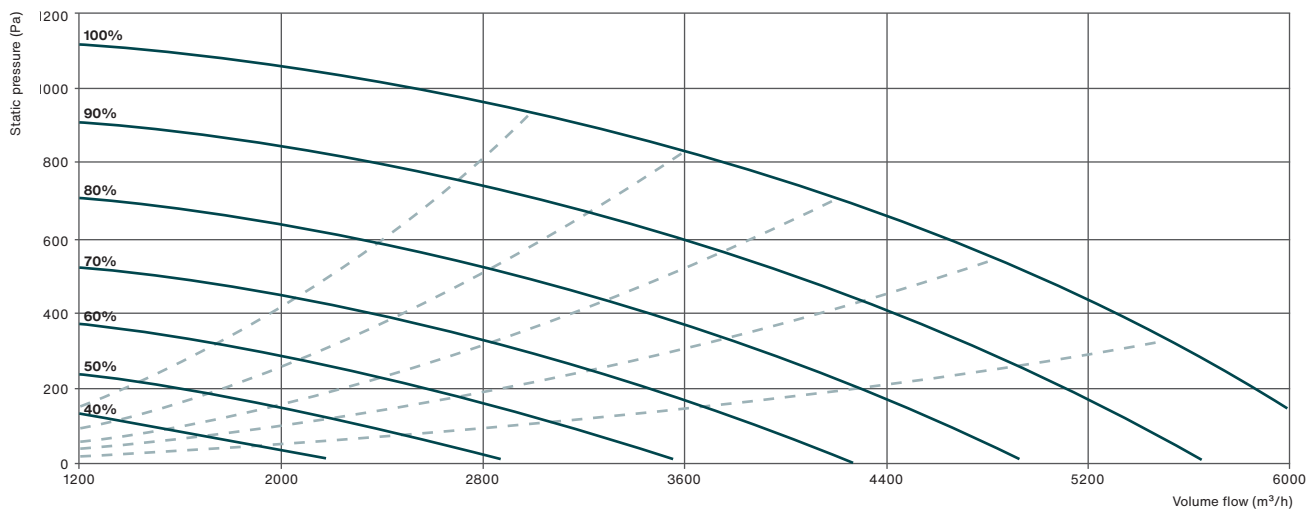

Zehnder Carma 9070

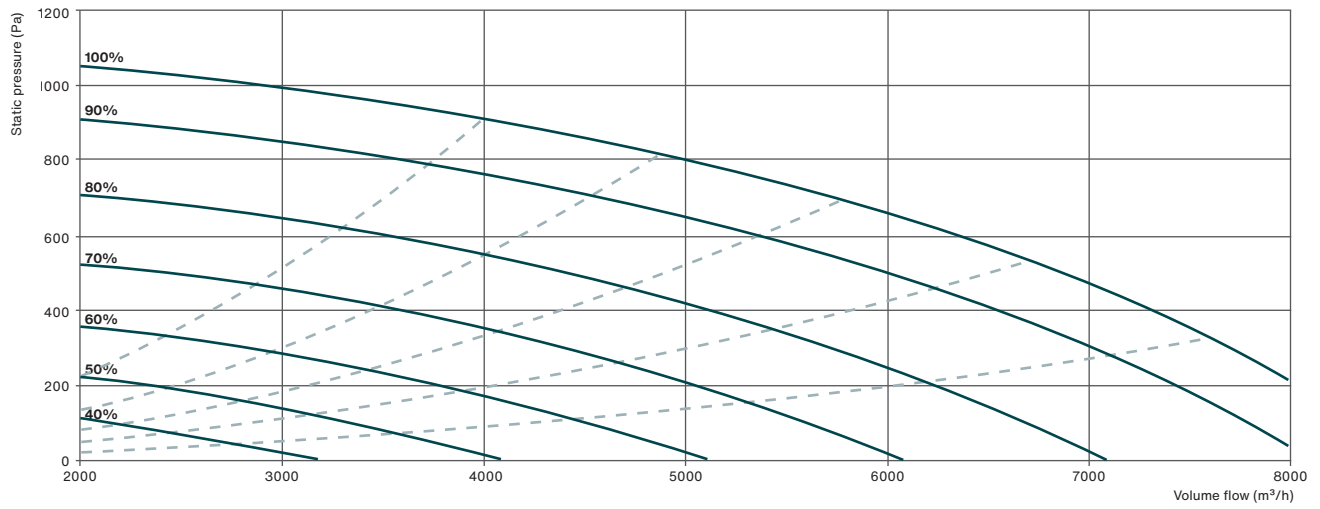

8.8. Modbus and BACnet tables

INPUT REGISTER				
Function	Description	EXO Type	Modbus address	BACnet address
Device status	Modbus: 0 = stop 1 = start 2 = start low fan speed 3 = start max. fan speed 4 = start normal fan speed 5 = in operation 8 = CO ₂ operation 9 = Night Cooling 11 = in the shutdown phase BACnet: 1 = stop 2 = start 3 = start low fan speed 4 = start max. fan speed 5 = start normal fan speed 6 = in operation 9 = CO ₂ operation 10 = Night Cooling 12 = in the shutdown phase	X	3	MSV,40003
Outdoor temperature	In °C	R	1	AV,40001
Runtime of the supply fan	In hours	R	4	AV,40004
Extract fan runtime	In hours	R	5	AV,40005
Supply air temperature	In °C	R	7	AV,40007
Extract air temperature	In °C	R	9	AV,40009
Supply air pressure	In Pa for the LOBBY model	R	13	AV,40013
Extract air pressure	In Pa for the LOBBY model	R	14	AV,40014
Supply air volume flow	In m ³ /h for the MAC2 / QUATTRO model	R	15	AV,40015
Extract air volume flow	In m ³ /h for the MAC2 / QUATTRO model	R	16	AV,40016
CO₂	In ppm for the DIVA / QUATTRO model	R	17	AV,40017
Rel. humidity	In %	R	23	AV,40023
Analogue output	0-10 V heating (water coil)	R	54	AV,40119
Analogue output	0-10 V heat exchanger	R	55	AV,40120
Analogue output	0-10 V cooling	R	56	AV,40121
Analogue output	0-10 V supply air	R	57	AV,40122
Analogue output	0-10 V extract air	R	58	AV,40123

HOLDING REGISTER					
Function	Description	EXO Type	Modbus address	BACnet address	Factory setting
Supply air setpoint	Configuration with constant supply air	R	1	AV,30001	18
Supply air setpoint	Configuration of ext. temp. controlled supply air control at -20 °C ext. temperature	R	10	AV,30010	25
Supply air setpoint	Configuration of ext. temp. controlled supply air control at -15 °C ext. temperature	R	11	AV,30011	24
Supply air setpoint	Configuration of ext. temp. controlled supply air control at -10 °C ext. temperature	R	12	AV,30012	23
Supply air setpoint	Configuration of ext. temp. controlled supply air control at -5 °C ext. temperature	R	13	AV,30013	23
Supply air setpoint	Configuration of ext. temp. controlled supply air control at 0 °C ext. temperature	R	14	AV,30014	22
Supply air setpoint	Configuration of ext. temp. controlled supply air control at +5 °C ext. temperature	R	15	AV,30015	20
Supply air setpoint	Configuration of ext. temp. controlled supply air control at +10 °C ext. temperature	R	16	AV,30016	18
Supply air setpoint	Configuration of ext. temp. controlled supply air control at +15 °C ext. temperature	R	17	AV,30017	18
Extract air setpoint	Configuration for extract air control	R	18	AV,30018	21
Setpoint supply air speed GV	In % for the ECO and DIVA model	R	424	AV,30424	70
Setpoint supply air speed PV	In % for the ECO and DIVA model	R	425	AV,30425	50
Extract air speed setpoint GV	In % for the ECO and DIVA model	R	426	AV,30426	70
Extract air speed setpoint PV	In % for the ECO and DIVA model	R	427	AV,30427	50
High supply air pressure setpoint	In Pa for the LOBBY model	R	24	AV,30024	150
Low supply air pressure setpoint	In Pa for the LOBBY model	R	25	AV,30025	150
Setpoint high extract air pressure	In Pa for the LOBBY model	R	26	AV,30026	150
Setpoint low extract air pressure	In Pa for the LOBBY model	R	27	AV,30027	150
Supply air flow rate GV setpoint	In m ³ /h for Model MAC2 and QUATTRO model	R	28	AV,30028	xxx
Supply air flow rate PV setpoint	In m ³ /h for Model MAC2 and QUATTRO model	R	29	AV,30029	xxx
Setpoint extract air flow rate GV	In m ³ /h for Model MAC2 and QUATTRO model	R	30	AV,30030	xxx
Setpoint extract air flow rate PV	In m ³ /h for Model MAC2 and QUATTRO model	R	31	AV,30031	xxx
CO₂ setpoint	In ppm for the DIVA and QUATTRO model	R	32	AV,30032	1000
Forced release of the unit operating mode	Modbus 0 = manual stop 1 = manual low fan speed 2 = manual normal fan speed 3 = auto	X	368	MSV,30368	3
	BACnet 1 = manual stop 2 = manual low fan speed 3 = manual normal fan speed 4 = auto				4

INPUT STATUS REGISTER				
Function	Description	EXO Type	Modbus address	BACnet address
Alarm overview	If 1 = ALARM	L	30	BV,20030
VAS error	If 1 = ALARM	L	33	BV,20033
VAR error	If 1 = ALARM	L	34	BV,20034
Filter error	If 1 = ALARM	L	38	BV,20038
Frost protection error	If 1 = ALARM	L	40	BV,20040
Fire protection error	If 1 = ALARM	L	42	BV,20042
Overheating electrical battery error	If 1 = ALARM	L	55	BV,20055
Battery error	If 1 = ALARM	L	80	BV,20080

9. Notes

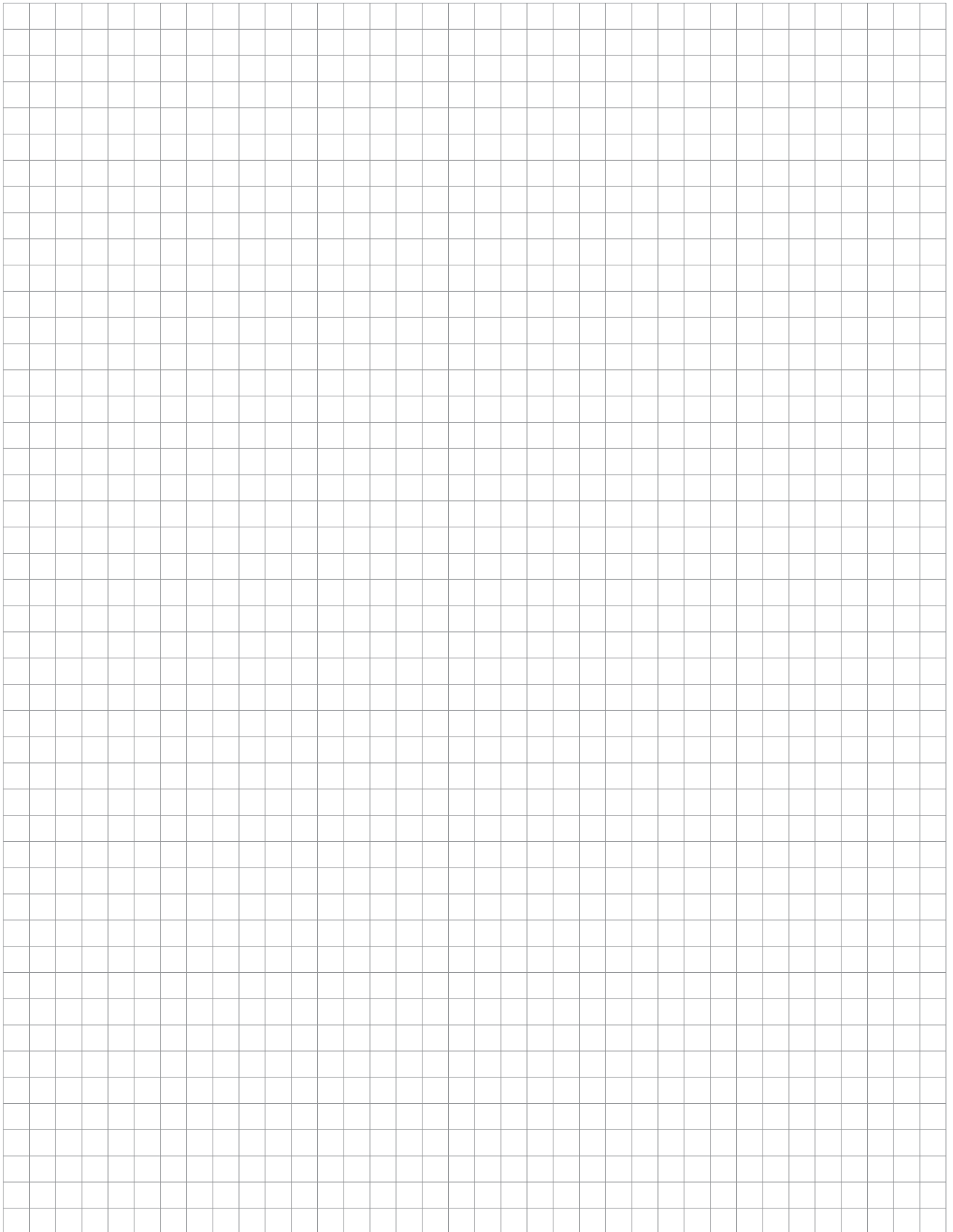

Notes



Mâcon Loché, on 29 August 2022

Ref: EU

EU-Declaration of conformity

We declare under our sole responsibility that the products

- ECOVOR™ - ECOBLUE™ - ECONIZER™- NOE™ - NOE LOBBY™
- MINIMAX™ - MINIBLUE™ - MINIBLUE LOBBY™ - MAXIPLUS™ - CITYCOOL™
- COMBIBOX CONCEPT™ - CMH - EVENTYS™
- CARMA™ - NEOTIME™ - FREETIME™ - EXAECO™- HEXAMOTION™- SILVERTOP™ - EVERSKEY™
- ELECTROPACK™ - AQUAPACK™ - LOBBY™ - SYSTEM TOP™ - SYSTEM DIV™ - WONDEROOM™
- CVFMI - CVFTI - CVFM - CVFT
- REFLEX™ - DIABLO™ - PYROSTAR™ - CDF
- EVERKIT™
- THERMOVER™

satisfy the provisions of the following applicable Directives and harmonised standards:

- Machinery Directive 2006/42/EC
- Low Voltage Directive 2014/35/EU
- EMC Directive - Electromagnetic Compatibility Directive 2014/30/EU
- RoHS II Directive - Directives on the restriction of the use of certain hazardous substances in electrical and electronic equipment 2011/65/EU and 2015/863/EU
- ErP Directive 2009/125/EC

Furthermore, for the products

COMBIBOX CONCEPT™ - CMH - CARMA™ - EXAECO™ - EVENTYS™ - FREETIME™ - NEOTIME™ -
HEXAMOTION™ - SILVERTOP™ - THERMOVER™ - EVERKIT™ (Dual flow unit section)

the following standards and specifications were applied:

- EN 1886: 2008 - Ventilation for buildings. Air handling units.
Mechanical performance
- EN 13053+A1: 2011 - Ventilation for buildings. Air handling units.
Rating and performance for units, components and sections.
This declaration is valid only for products installed according to the supplied instructions and
having undergone no modification.

A handwritten signature in black ink, appearing to read "Hervé Nuzzo", is written over a large, faint, oval-shaped watermark or background mark.

Hervé Nuzzo,
President

CALADAIR INTERNATIONAL

61 Rue Saint-Véran
71000 Macon Loche

Tél. : 03 85 36 82 00
Fax : 03 85 36 82 01

Company

1st line of address ▪ Town ▪ Country
email ▪ web